

# FUßRASTENVERGRÖßERUNG ULTIMATE

Footpeg enlarger | Agrandissement des repose-pieds | Ampliación de los reposapiés | Ingrandimento delle pedane

Art.-Nr: 13322-000



**Bei Fertigungstoleranzen der originalen Fußrasten können die Fußrastenvergrößerungen durch die beiliegenden Distanzscheiben (Nr.5) und die Madenschrauben (Nr.6) angepasst werden.**

*If the original footpegs have manufacturing tolerances, the footpeg enlarger can be adjusted using the enclosed spacers (no. 5) and grub screws (no. 6).*

*Si les repose-pieds d'origine présentent des tolérances de fabrication, l'élargisseur de repose-pieds peut être ajusté à l'aide des entretoises (n° 5) et des vis sans tête (n° 6) fournies.*

## LEGENDE / Key / file Légende

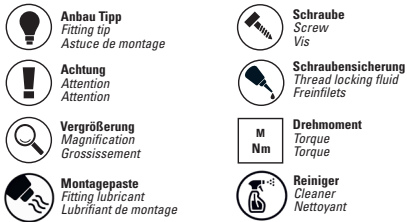

#	Bauteil component composant	DE Die Farben der Abbildungen dienen nur der Veranschaulichung. EN The colors are for illustrating purposes only. FR Les couleurs utilisées sont à titre indicatif seulement.	DIN	ISO	Menge quantity quantité
1	Fußrastenvergrößerung / Footpeg enlarger				2
2	Linienflanschschraube / Lens head screw M6x18		7381	7381	4
3	Spannhülse / Clamping sleeve				4
4	Sechskantmutter / Hex nut M6		985	10511	4
5	Distanzscheibe / Spacer				6
6	Madenschraube / Grub screw M6x6		913	4026	4

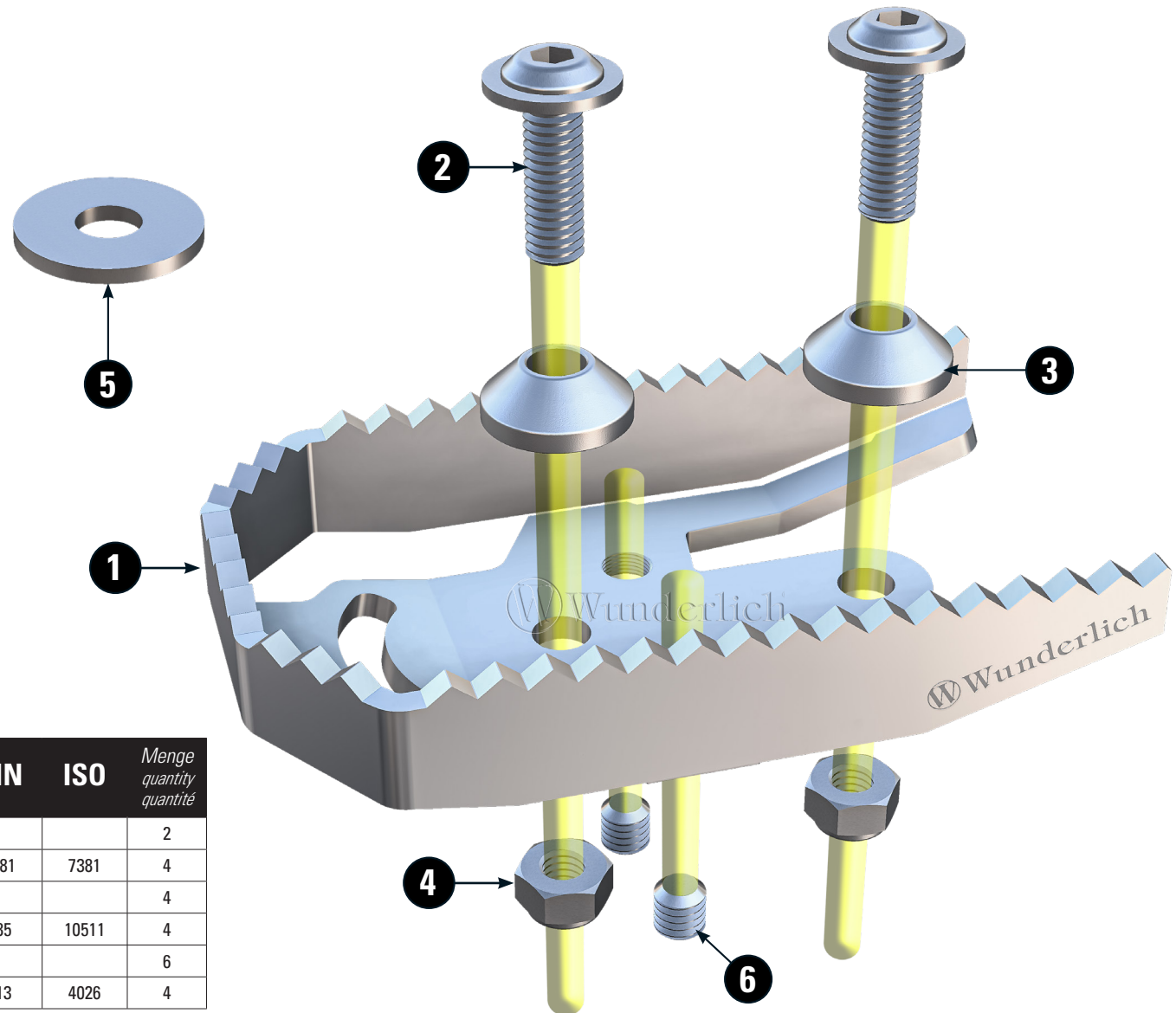

11.02.2025



