

MOTORSCHUTZ

Engine protection | Protector de motor | Protection moteur | Protezione motore

Art.-Nr: 14220-00x

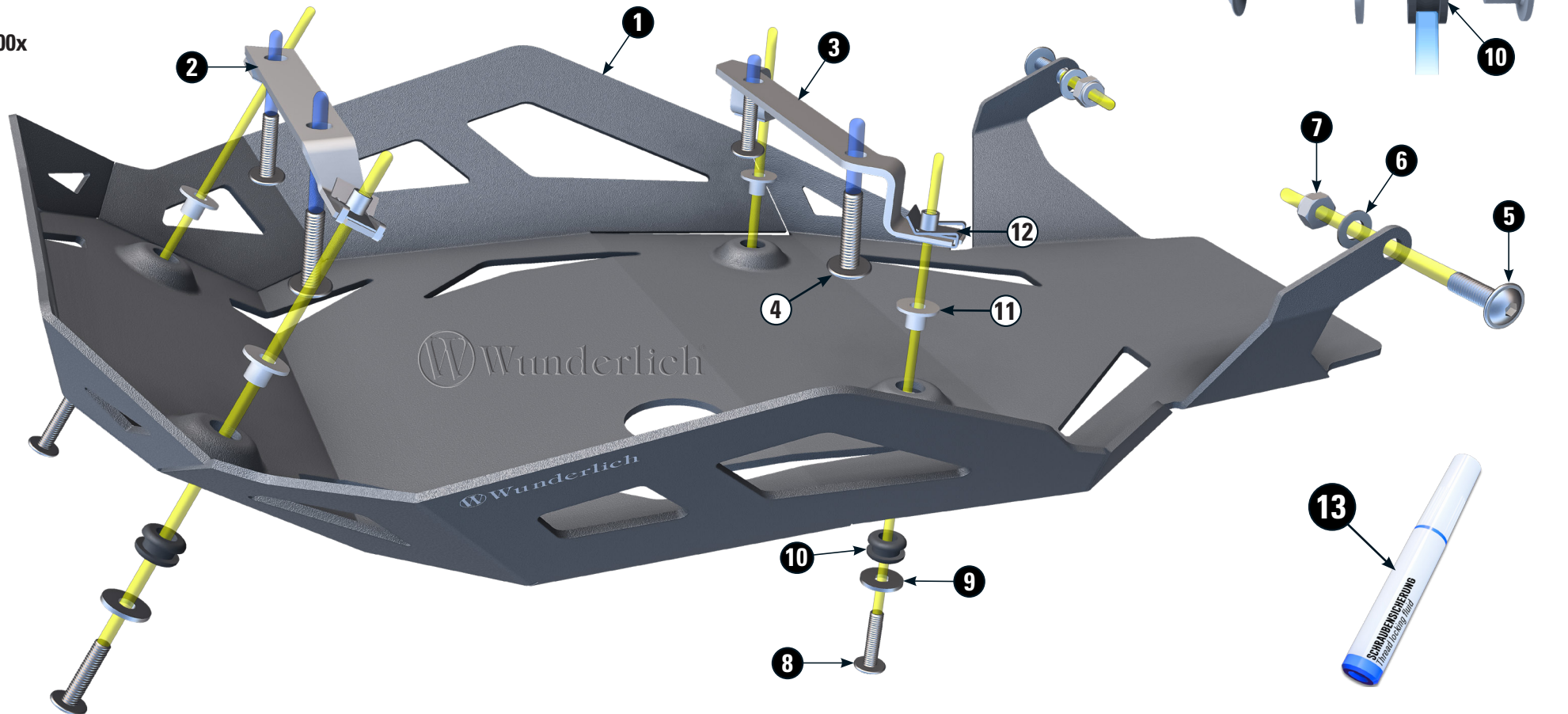

#	Bauteil component composant	DE Die Farben der Abbildungen dienen nur der Veranschaulichung. EN The colors are for illustrating purposes only. FR Les couleurs utilisées sont à titre indicatif seulement.	DIN	ISO	Menge quantity quantité
1	Motorschutz / Engine protection				1
2	Halter (vorne) / Bracket (front)				1
3	Halter (hinten) / Bracket (rear)				1
4	Linsenflanschschraube / Lens head screw M8x20		7381	7381	4
5	Linsenflanschschraube / Lens head screw M8x25		7381	7381	2

6	U-Scheibe / Washer M8	125	7089	2
7	Sechskantmutter / Hex nut M8	985	10511	2
8	Linsenflanschschraube / Lens head screw M6x25	7381	7381	4
9	U-Scheibe / Washer M6	9021	7093	4
10	Gummitülle / rubber grommet			4
11	Stufenhülse / stepped bushing			4
12	Blechmutter / sheet metal nut			4
13	Schraubensicherung / Thread locking fluid			1

LEGENDE / Key / file Légende

Anbau Tipp
Fitting tip
Astuce de montage

Achtung
Attention
Attention

Vergrößerung
Magnification
Grossissement

Montagepaste
Fitting lubricant
Lubrifiant de montage

Schraube
Screw
Vis

Schraubensicherung
Thread locking fluid
Freinfiets

Drehmoment
Torque
Torque

Reiniger
Cleaner
Nettoyant



1



**Achten Sie beim Montieren der Halter darauf, dass diese gerade sitzen.
Drücken Sie die Halter beim Verschrauben leicht nach hinten.**
*Make sure the brackets are aligned straight during installation.
Press them slightly backwards while tightening the screws.*
*Veillez à ce que les supports soient bien droits lors du montage.
Poussez-les légèrement vers l'arrière lors du vissage.*

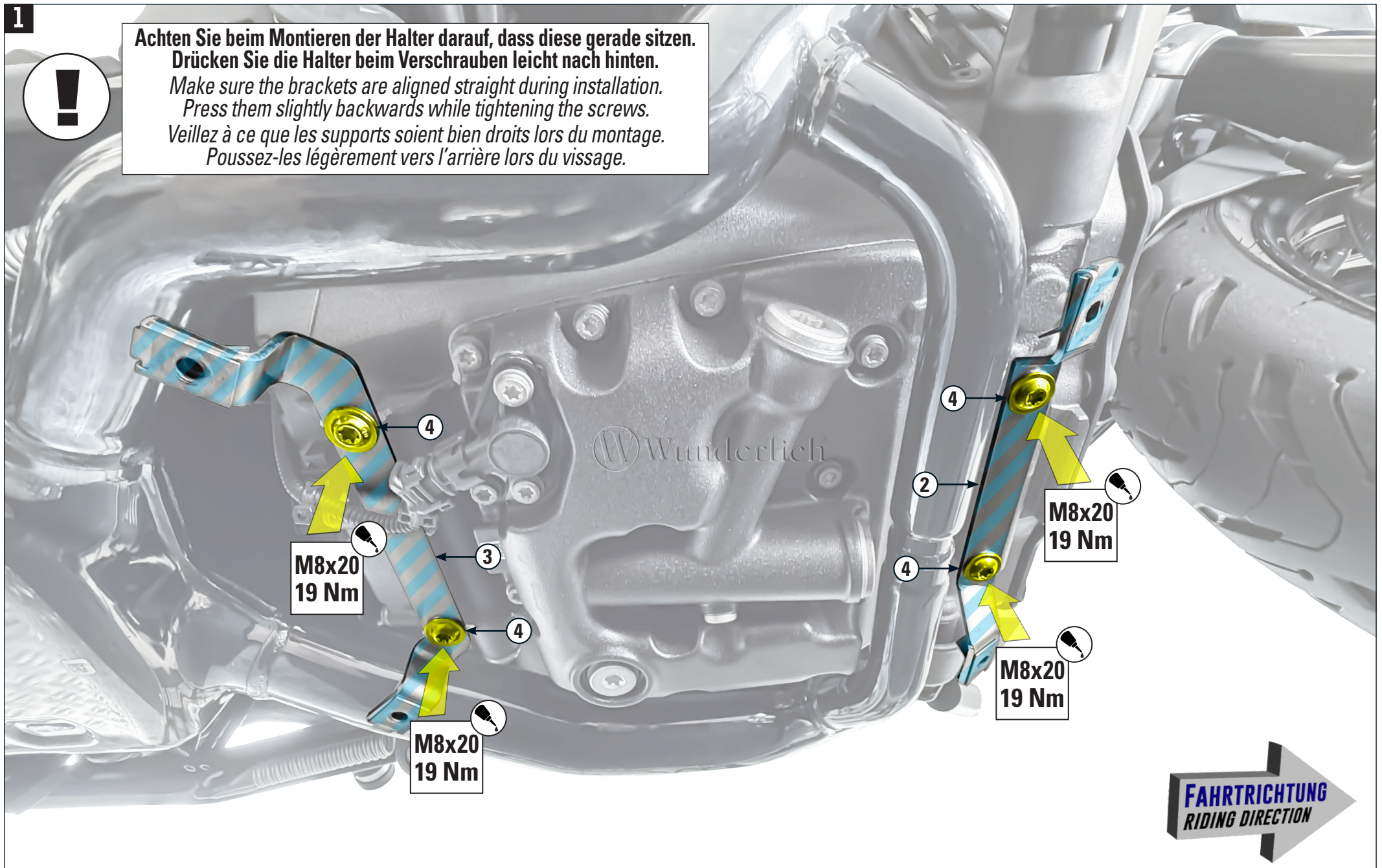

2

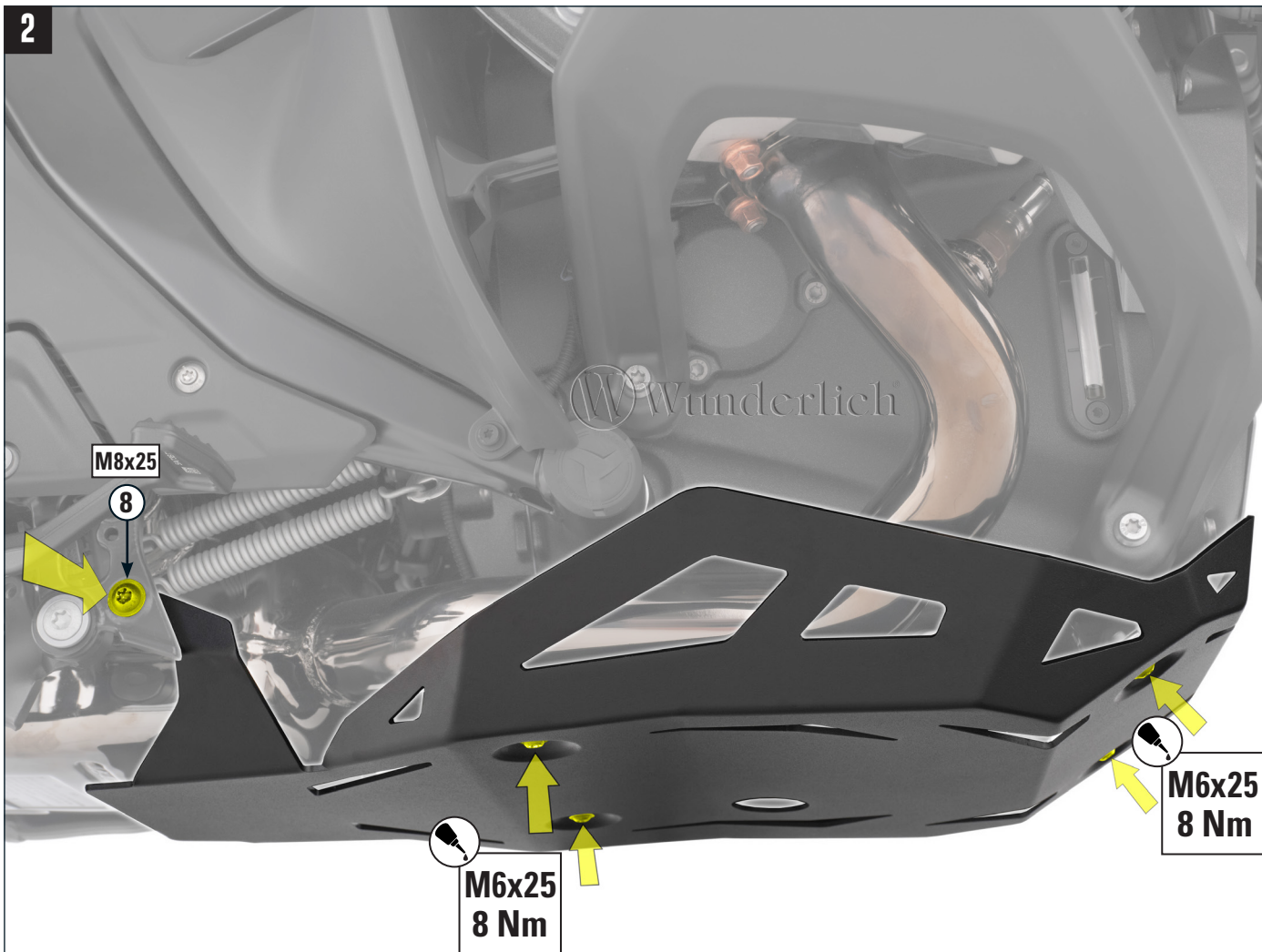

**Bitte alle Anbauteile lose am Fahrzeug vormontieren und ausrichten.
Erst danach die Schrauben nach Vorgabe anziehen.**

First, tighten all screws only loosely. After mounting all parts, the screws should be tightened to the torque specified.

Tout d'abord, ne serrez pas toutes les vis sans les serrer. Après avoir monté toutes les pièces, les vis doivent être serrées au couple spécifié.

3

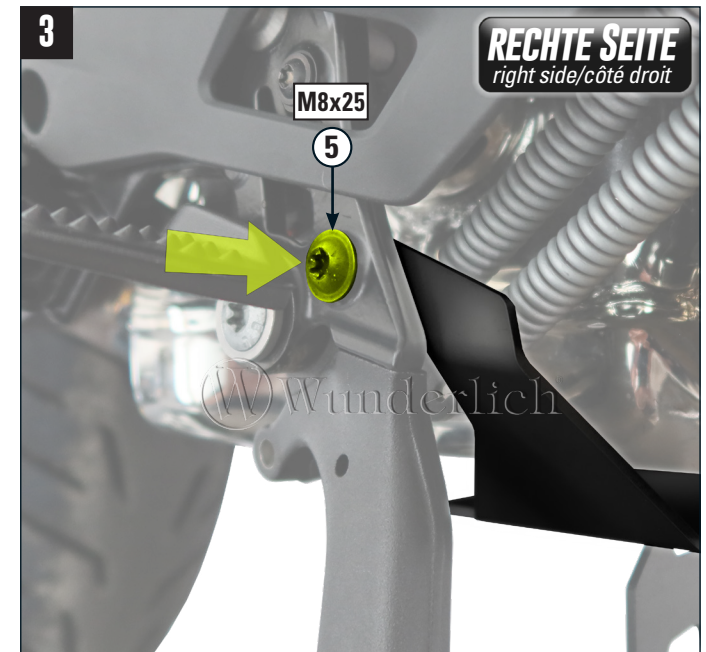

4

