

# RAHMENABDECKUNG

Frame cover | Couverture de cadre | Cubierta de marco | Copertura del telaio

Art.-Nr: 20800-202

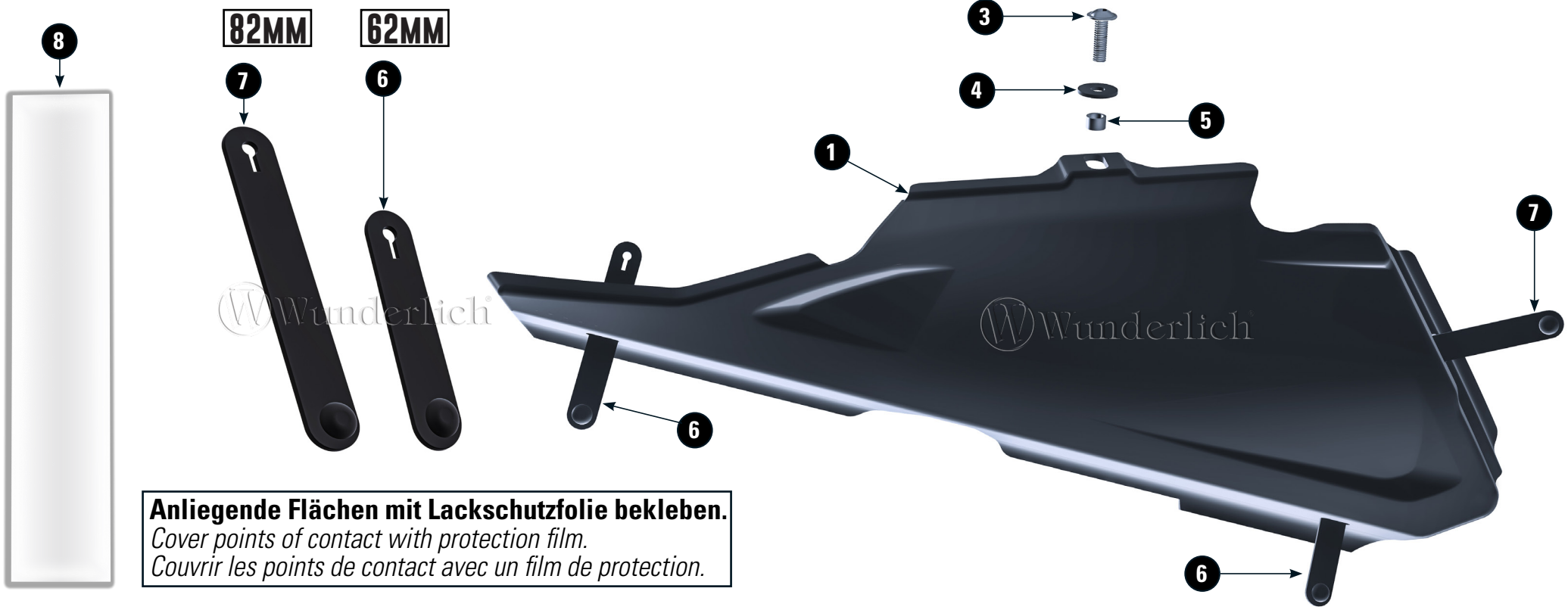

**Anliegende Flächen mit Lackschutzfolie bekleben.**  
 Cover points of contact with protection film.  
 Couvrir les points de contact avec un film de protection.

#	BEZEICHNUNG / DESCRIPTION	DE EN FR	Die Farben der Abbildungen dienen nur der Veranschaulichung. The colors are for illustrating purposes only. Les couleurs utilisées sont à titre indicatif seulement.			DIN	ISO	MENGE QUANTITY
1	Rahmenabdeckung (rechts) / Frame cover (right side)						1	
2	Rahmenabdeckung (links) / Frame cover (left side)						1	
3	Linsenflanschschraube / lens head screw		M6x20	8Nm	7381SA2	7381SA2	2	
4	U-Scheibe / washer		M6		9021SA2	7093	2	
5	Hülse / sleeve		5,5mm				2	
6	Gummi-Kabelbinder / rubber zip ties		62mm				4	
7	Gummi-Kabelbinder / rubber zip ties		82mm				2	
8	Lackschutzfolie/protection film		20cm				5	

LEGENDE/KEY/FILE LÉGENDE

- Anbau Tipp**  
Fitting tip  
Astuce de montage
- Achtung**  
Attention  
Attention
- Vergrößerung**  
Magnification  
Grossissement
- Montagepaste**  
Fitting lubricant  
Lubrifiant de montage
- Schraube**  
Screw  
Vis
- Schraubensicherung**  
Thread locking fluid  
Freifilets
- M Nm**  
Drehmoment  
Torque  
Torque



