

Verbundstrebe für Offroad Bracing bow for Offroad

für Motorschutzbügel 26442-00x
for engine guard 26442-00x



Wunderlich[®]
complete your BMW.

handmade in
germany



INOX
STAINLESS STEEL

für/for: **BMW R 1250 GS** ab Baujahr 2018 / from date of manufacture 2018

Artikel Nr.: / Item-no.:

26443-000 Edelstahl/Stainless Steel

26443-002 schwarz

26443-004 weiss

26443-005 blau

Produktionsdatum
date of production



1 Verbundstrebe

Schraubensatz:

2x VA-Torxschrauben M8x25mm
2x VA-U-Scheiben Ø8,4

1 Bracing bow

Screw kit:

2x VA-Torx screws M8x25mm
2x VA-washer Ø8,4

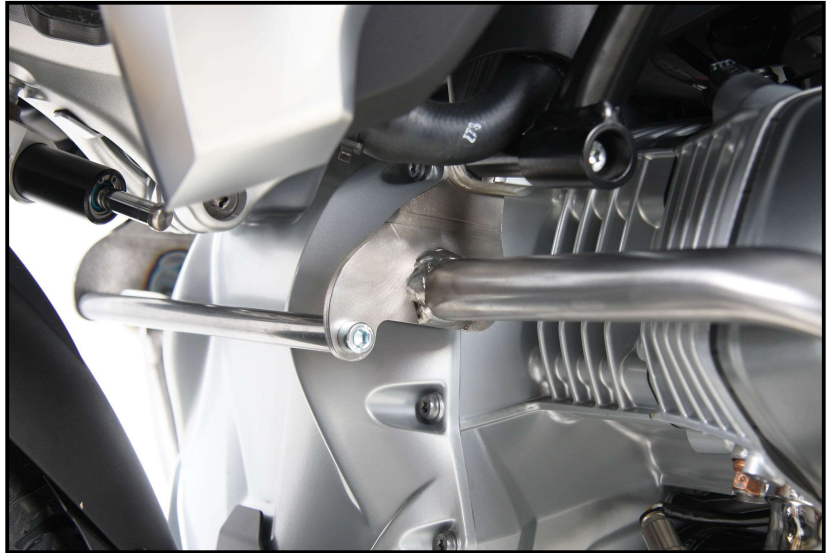

Verschraubung des Verbindungsbügels:

Zwischen den Bohrungen der oberen Haltetasche des Motorschutzbügels. Dieser verläuft quer vor dem Motorblock. Zur Verschraubung die Torxschrauben M8x25 sowie U-Scheiben ø8,4 verwenden.

Bei Modell BMW R 1250 GS HP:

Untere Bohrungen nutzen.

Bei Modell BMW R 1250 GS:

Obere Bohrungen nutzen.

Fastening of the bracing bow:

Between the left and the right crash bar in front of the engine block.

Use torx screws M8x25 with washers ø8,4 mm.

For model BMW R 1250 GS HP:

Use lower holes.

For model BMW R 1250 GS:

Use upper holes.

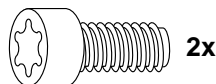
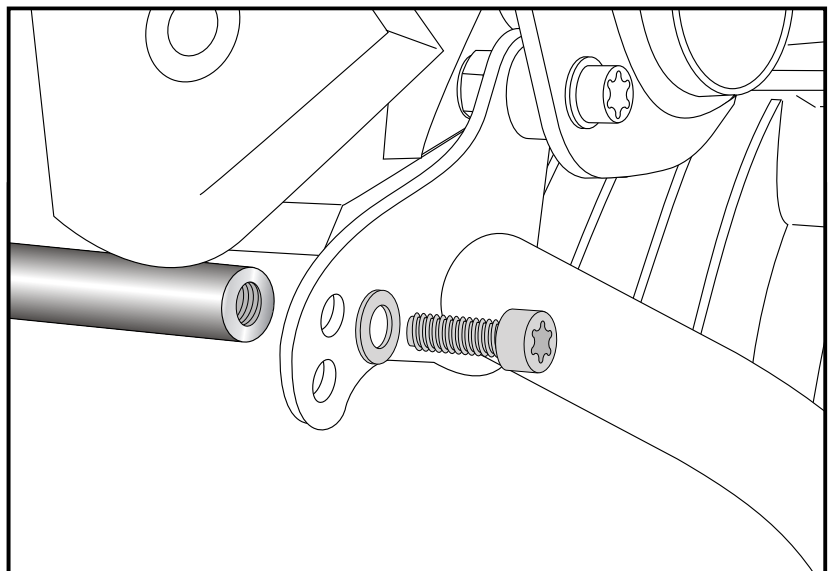

Wunderlich GmbH
Kranzweiherweg 12
53489 Sinzig-Gewerbepark

Tel. 0049 (0) 02642-9798-0
Fax 0049 (0) 02642-9798-33
www.wunderlich.de