

HECKABSCHLUSS MIT KENNZEICHENHALTER

Rear Closure with license plate holder | Finition arrière avec support de plaque d'immatriculation | Parte trasera con soporte para matrícula | Posteriore con portatarga

Art.-Nr: 44131-10x

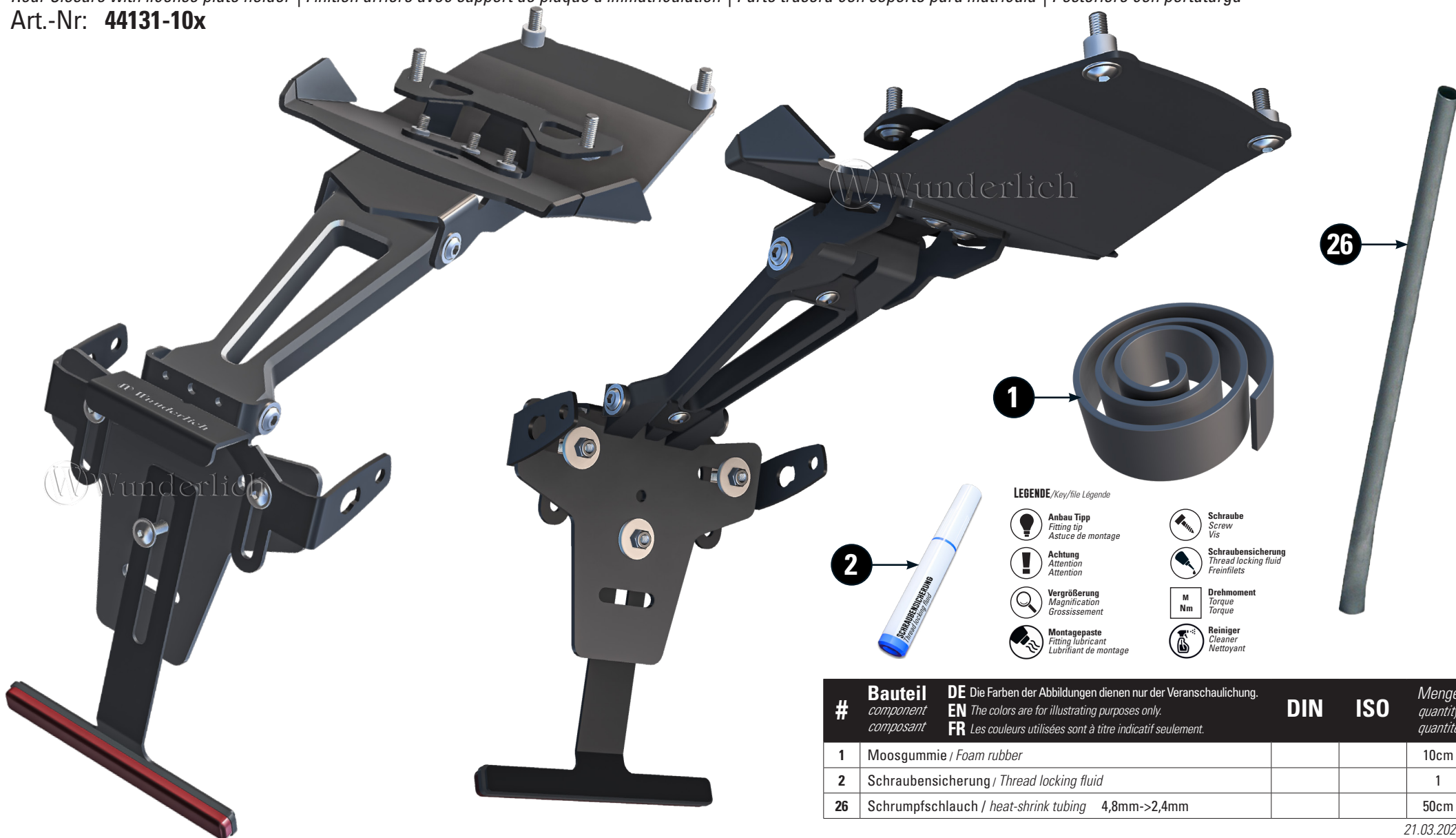

LEGENDE / Key / file Légende

- Anbau Tipp**
Fitting tip
Astuce de montage
- Achtung**
Attention
Attention
- Vergößerung**
Magnification
Grossissement
- Montagepaste**
Fitting lubricant
Lubrifiant de montage
- Schraube**
Screw
Vis
- Schraubensicherung**
Thread locking fluid
Freinfiets
- Drehmoment**
Torque
Torque
- Reiniger**
Cleaner
Nettoyant

#	Bauteil component composant	DE Die Farben der Abbildungen dienen nur der Veranschaulichung. EN The colors are for illustrating purposes only. FR Les couleurs utilisées sont à titre indicatif seulement.	DIN	ISO	Menge quantity quantité
1	Moosgummie / Foam rubber				10cm
2	Schraubensicherung / Thread locking fluid				1
26	Schrumpfschlauch / heat-shrink tubing 4,8mm->2,4mm				50cm

21.03.2025



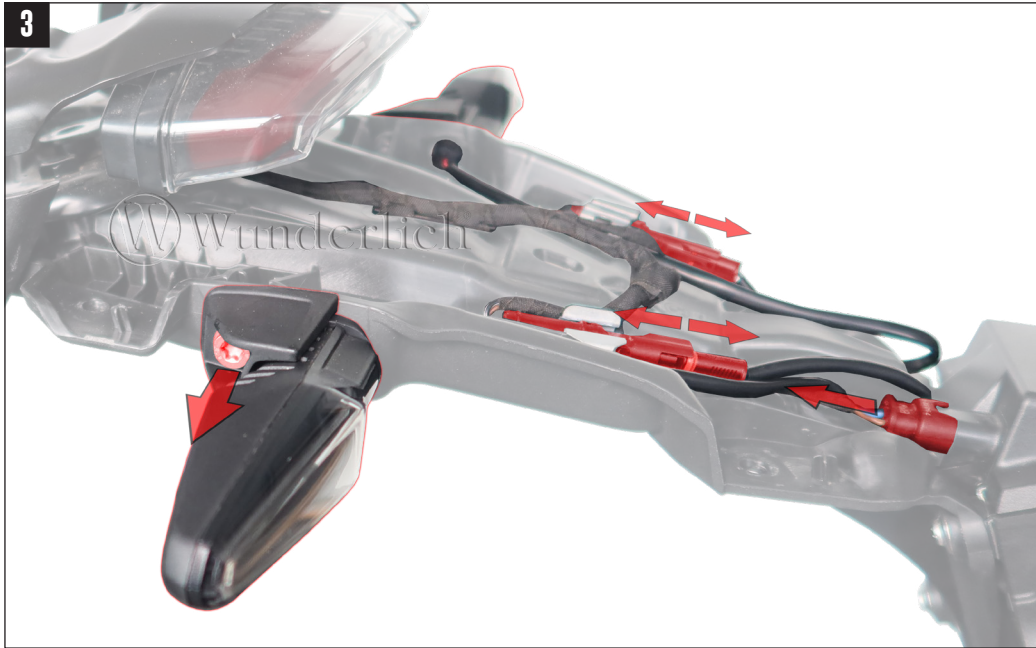
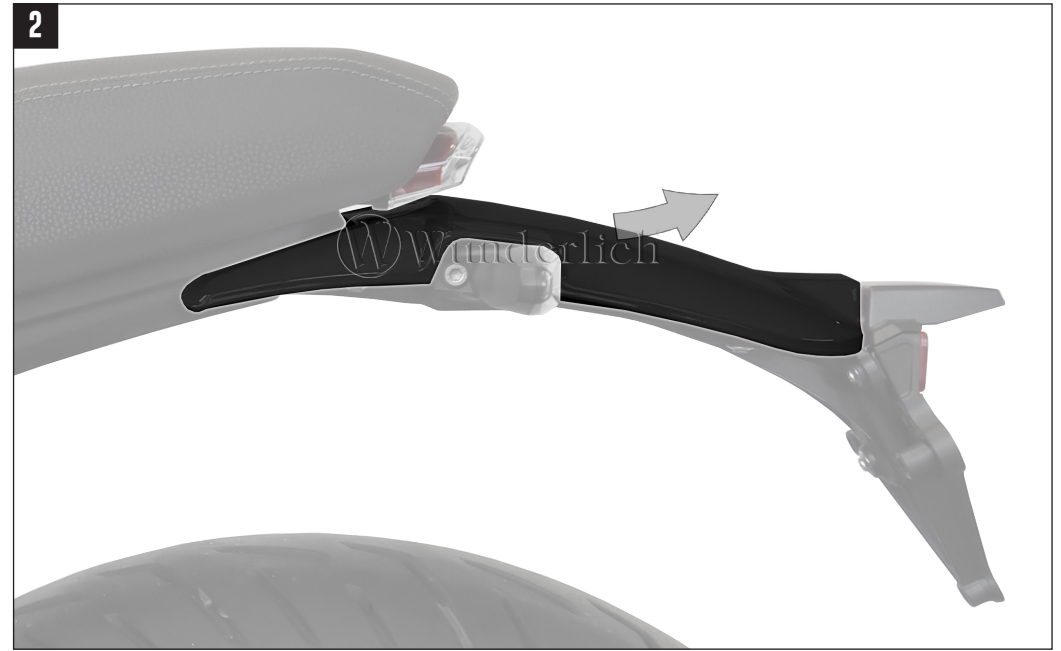

#	Bauteil component composant	DE Die Farben der Abbildungen dienen nur der Veranschaulichung. EN The colors are for illustrating purposes only. FR Les couleurs utilisées sont à titre indicatif seulement.	DIN	ISO	Menge quantity quantité
3	Heckabschluss / Rear Closure				1
4	Halter Heckabschluss / Rear Closure bracket				1
5	Linsenflanschschraube / Lens head screw M6x16		7381	7381	2
6	Hülse / Sleeve 8mm				2
7	Linsenflanschschraube / Lens head screw M6x20		7381	7381	2

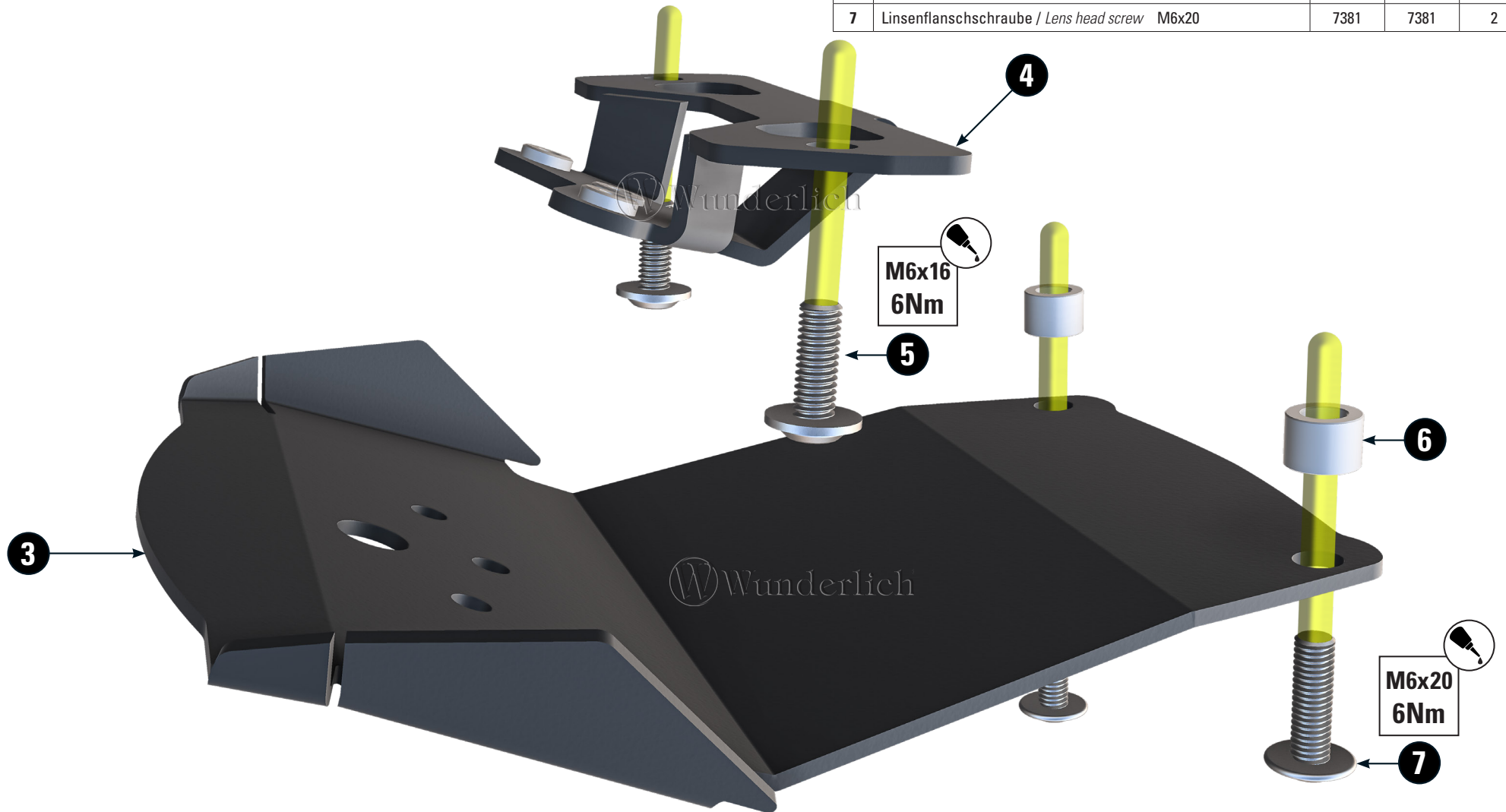

6

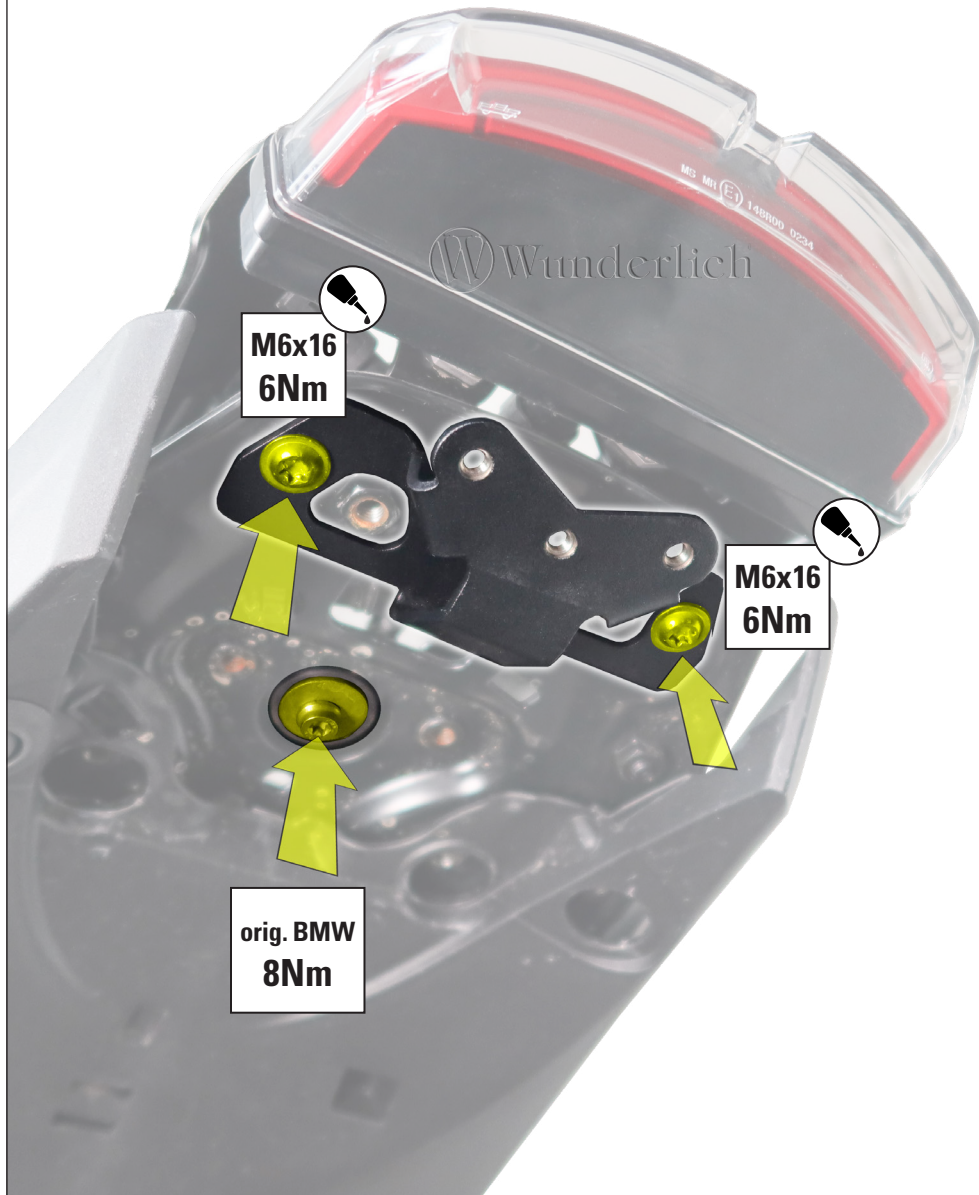

7



#	Bauteil component composant	DE Die Farben der Abbildungen dienen nur der Veranschaulichung. EN The colors are for illustrating purposes only. FR Les couleurs utilisées sont à titre indicatif seulement.	DIN	ISO	Menge quantity quantité
8	Grundhalter Kennzeichenträger / Base bracket				1
9	Linsenflanschschrabe / Lens head screw M5x16		7381	7381	3
10	Kennzeichenträger (Halte 2) / Bracket 2				1
11	Linsenflanschschrabe / Lens head screw M6x12		7381	7381	4
12	Kabelhalter 1 / Cable bracket 1				1
13	Kabelhalter 2 / Cable bracket 2				1
14	Linsenflanschschrabe / Lens head screw M4x6		7381	7381	2

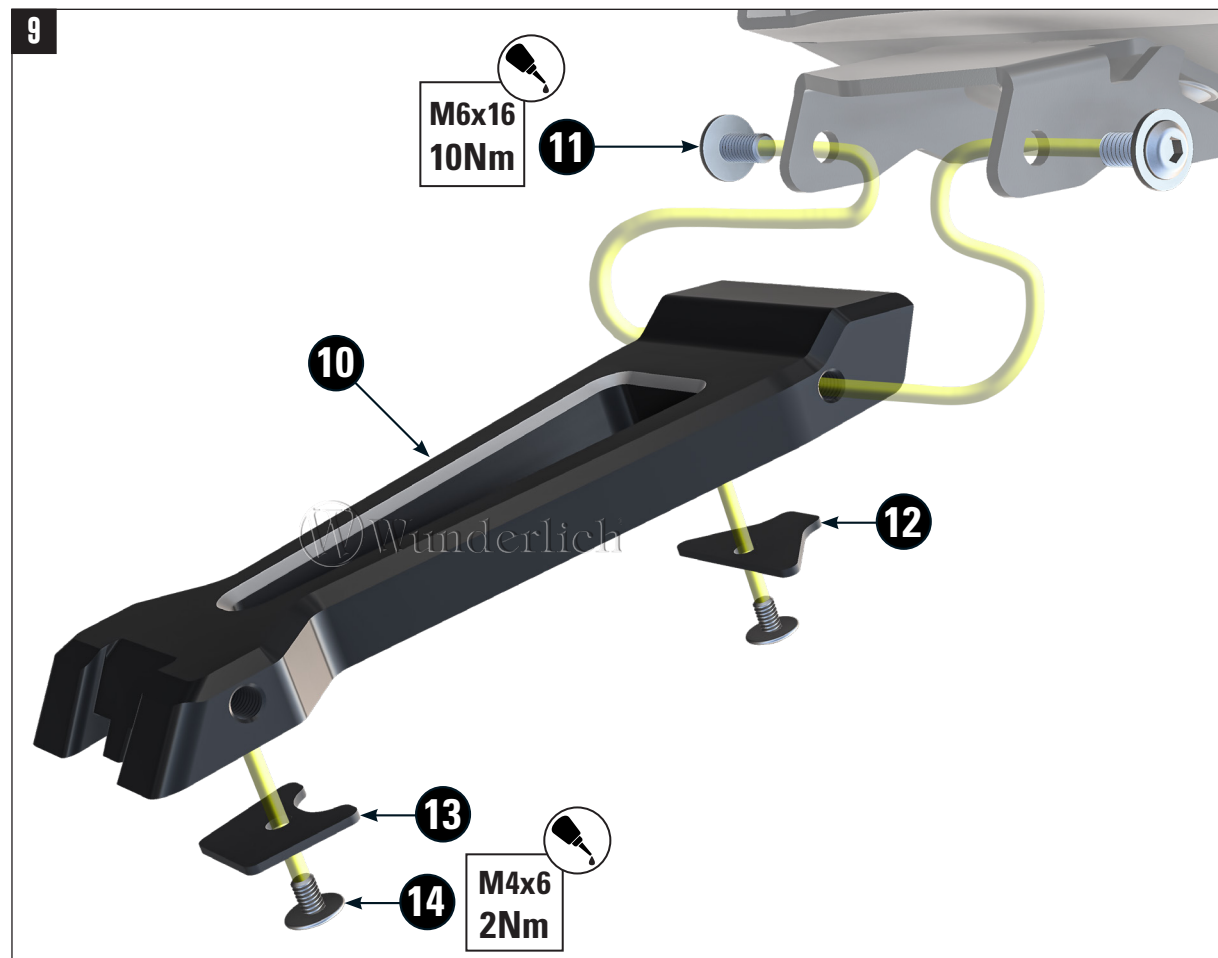
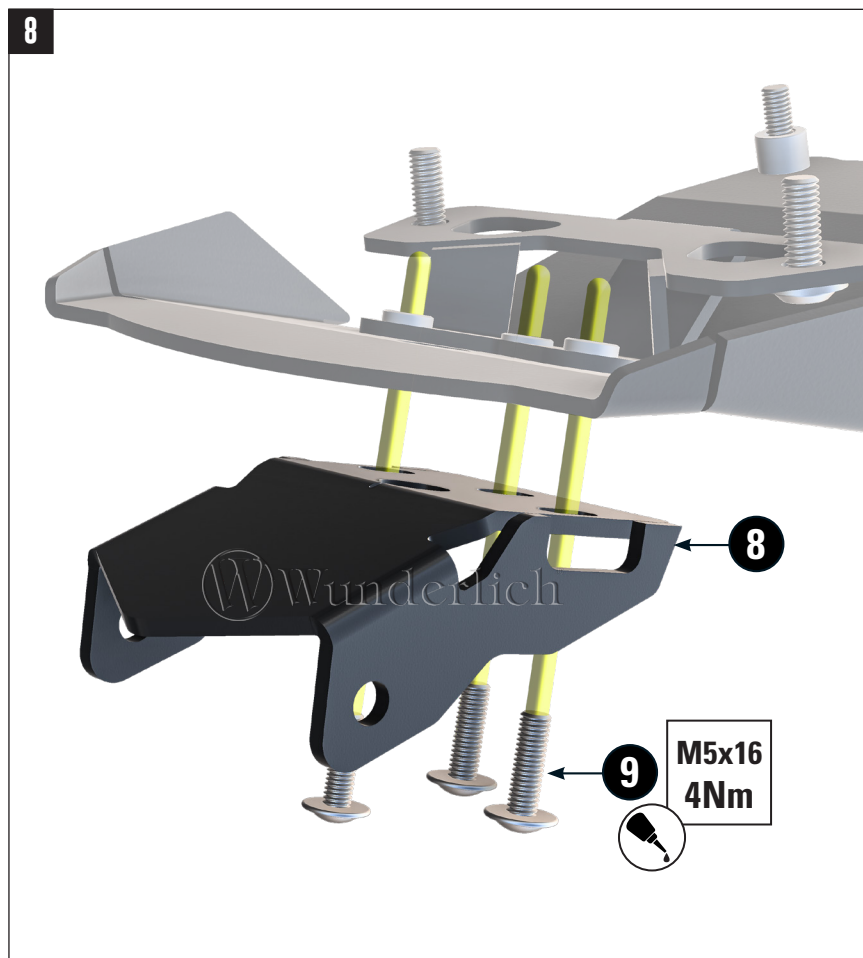

#	Bauteil component composant	DE Die Farben der Abbildungen dienen nur der Veranschaulichung. EN The colors are for illustrating purposes only. FR Les couleurs utilisées sont à titre indicatif seulement.	DIN	ISO	Menge quantity quantité
11	Linsenflanschschraube / Lens head screw M6x12		7381	7381	4
15	Kennzeichenträger-Platte / license plate bracket				1
16	Halter Kennzeichenbeleuchtung / license plate light bracket				1
17	LED Kennzeichenbeleuchtung / LED license plate light				1
18	Linsenflanschschraube / Lens head screw M6x16		7381	7381	2
19	U-Scheibe / Washer M6		125	7089	2
20	Sechskantmutter / Hex nut M6		985	10511	2
21	Linsenflanschschraube / Lens head screw M5x14		7381	7381	3
22	U-Scheibe / Washer M5		9021	7093	3
23	Sechskantmutter / Hex nut M5		985	10511	3
24	Halter Reflektro / reflector bracket				1
25	Reflektor (rot) / reflector				1

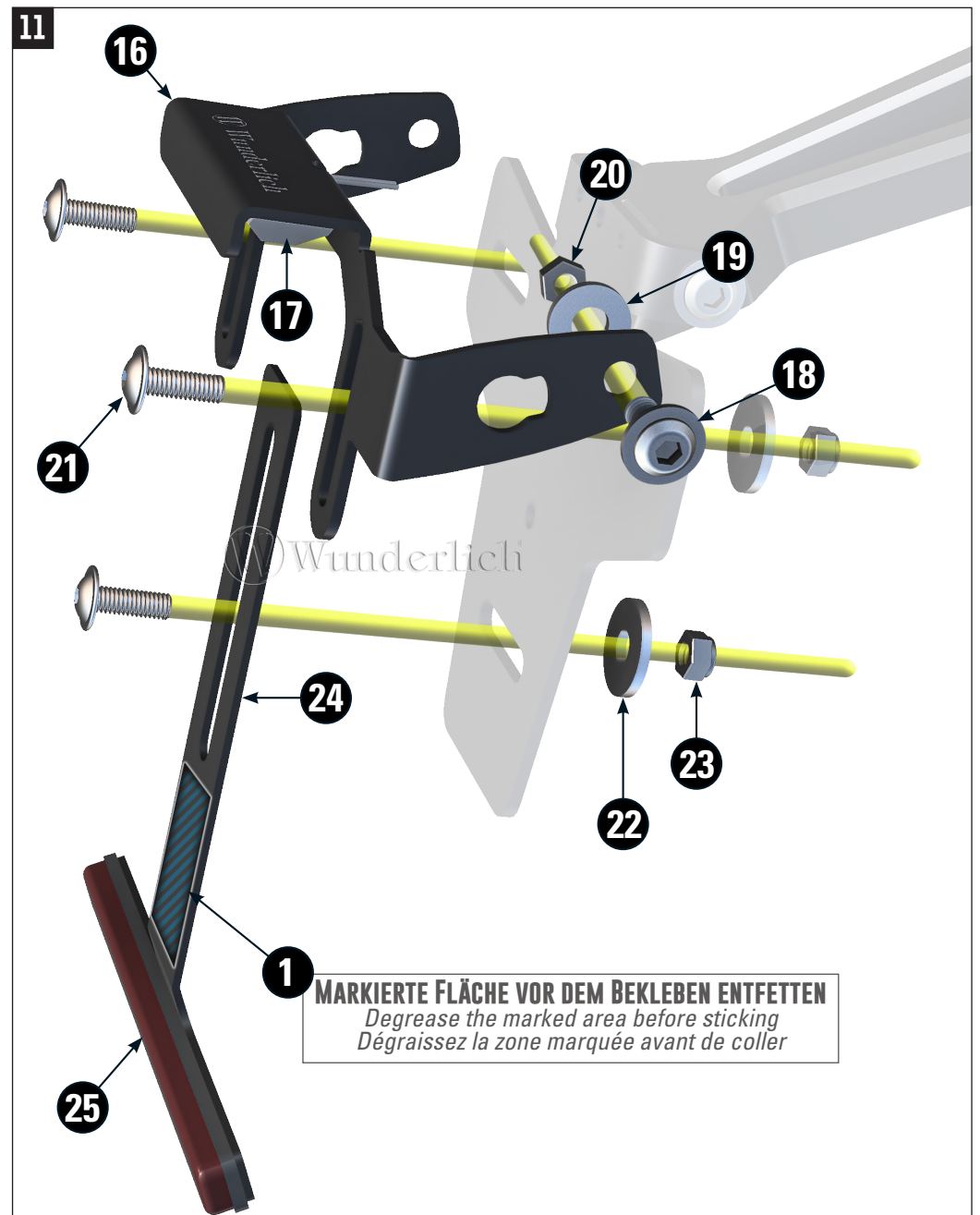
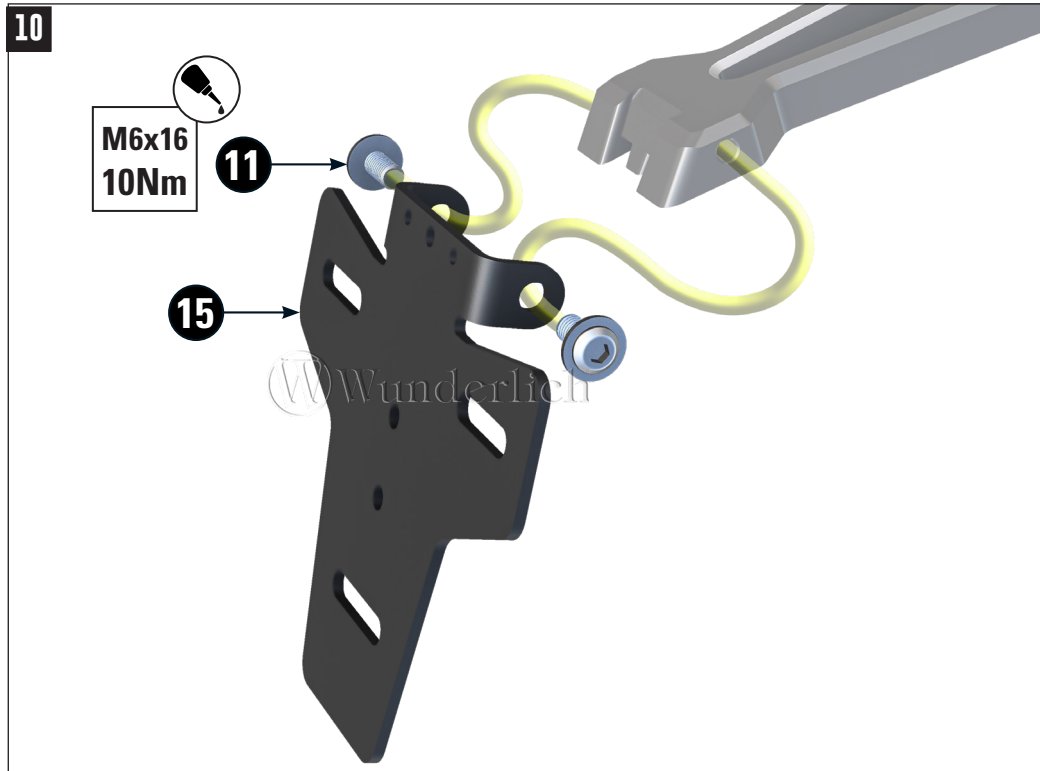

Kennzeichen nach StVZO des jeweiligen Landes ausrichten. Auf ausreichenden Abstand zum Reifen achten.
Align license plate according to the StVZO of the respective country. Observe an adequate distance to the tire.
Aligner la plaque d'immatriculation selon le StVZO du pays concerné. Respectez une distance suffisante par rapport au pneu.



Verkabelung der Kennzeichenbeleuchtung.

Wiring of the license plate light.

Câblage de l'éclairage de la plaque d'immatriculation.



W Wunderlich