

# KOFFERTRÄGER X-RACK LIGHT

Case carrier | Portamaletas | Porte-bagages | Supporto per valigie

Art.-Nr. 44137-002

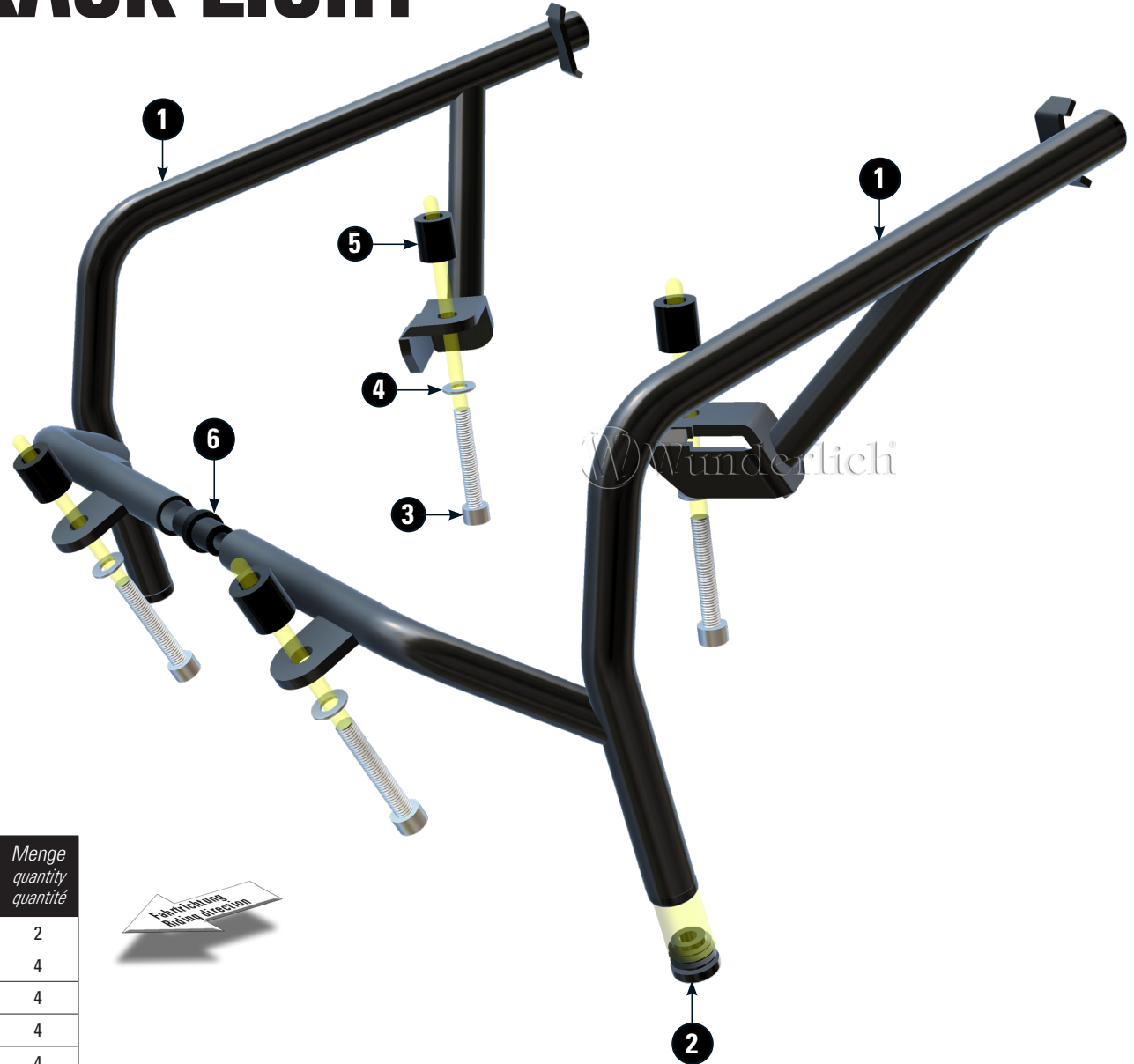

## LEGENDE / Key / file Légende

**Anbau Tipp**  
Fitting tip  
Astuce de montage

**Achtung**  
Attention  
Attention

**Vergrößerung**  
Magnification  
Grossissement

**Montagepaste**  
Fitting lubricant  
Lubrifiant de montage

**Schraube**  
Screw  
Vis

**Schraubensicherung**  
Thread locking fluid  
Freinilets

**Drehmoment**  
Torque  
Torque

**Reiniger**  
Cleaner  
Nettoyant

#	Bauteil component composant	DE Die Farben der Abbildungen dienen nur der Veranschaulichung. EN The colors are for illustrating purposes only. FR Les couleurs utilisées sont à titre indicatif seulement.	DIN	ISO	Menge quantity quantité
1	Rechter & linker Kofferträger / Right & left luggage rack				2
2	Lamellenstopfen / Lamella plugs				4
3	Zylinderschraube / Cylinder head screw M8x45 (Torx)		912Z	4762	4
4	U-Scheibe / Washer M8		125Z	7089	4
5	Alu Distanz (schwarz eloxiert) / Alu sleeve (schwarz eloxiert) ØD 18,0 - Ød 10,0 - h 20,0 mm				4
6	Verbindungsstopfen / Connector plug				1
7	Schraubensicherung / Thread locking fluid				1



07.12.25



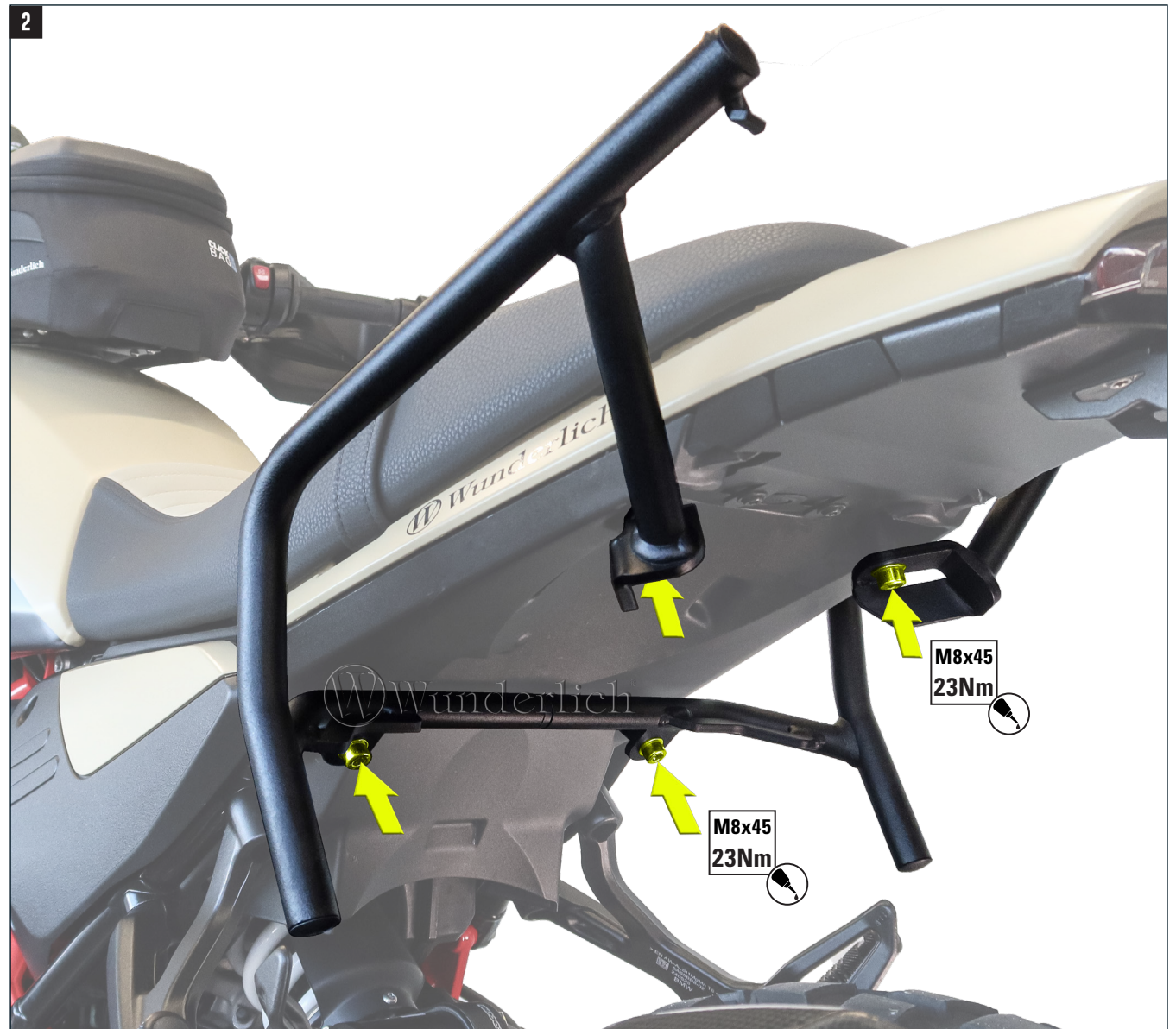

**Träger lose vormontieren und erst nach dem Ausrichten mit angegebenen Drehmoment festziehen.**

*Pre-assemble the bracket and support loosely and only tighten to the specified torque after alignment.*

*Pré-assembler le support et l'étrier sans les serrer et ne les serrer au couple spécifié qu'après l'alignement.*

3



**Der Sozusbetrieb kann bei den Koffervarianten und Taschen eingeschränkt sein. Bitte prüfen (Abbildung 3).**

*The passenger may be restricted in terms of the case variants and bags. Please check (Figure 3).*

*Le siège passager peut être soumis à certaines restrictions en termes de variantes de valises et de sacs. Veuillez vérifier (Figure 3).*

4





**Die Verriegelung und Befestigung des Koffers, vor Fahrtantritt prüfen.  
Ungleichmäßiges oder unsachgemäßes Beladen beeinflusst das Fahrverhalten negativ.**

*Check that the case is locked and secured before setting off.*

*Uneven or improper loading can affect the driving behaviour in a negative way.*

*Vérifiez que le coffre est bien fermé et sécurisé avant de prendre la route.*

*Un chargement inégal ou incorrect peut avoir un impact négatif sur le comportement routier.*