

HECKUMBAU

Tail section with license plate holder | Transformation arrière avec porte-plaque minéralogique | Modificación de colín con portamatrículas | Conversione posteriore con portatarga

Art.-Nr: 44903-102

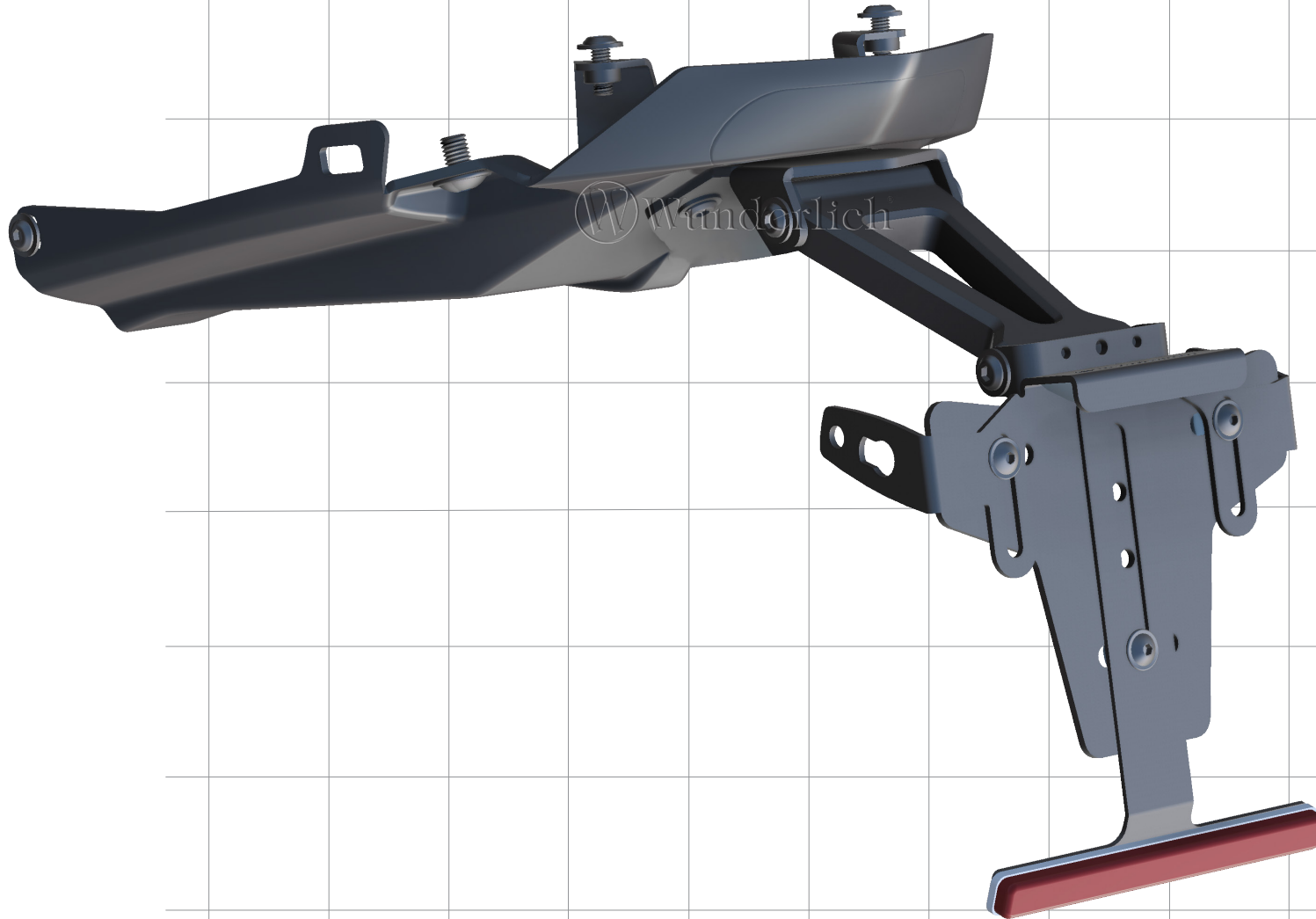

12/08/2025



#	BEZEICHNUNG / DESCRIPTION	DE EN FR	Die Farben der Abbildungen dienen nur der Veranschaulichung. The colors are for illustrating purposes only. Les couleurs utilisées sont à titre indicatif seulement.			DIN	ISO	MENGE QUANTITY
1	Heckabdeckung / Rear fairing						1	
2	Halteplatte 1 / Bracket 1						1	
3	Linsenflanschschraube (schwarz) / Lens head screw (black)		M6x14	7381	7381		5	
4	Linsenflanschschraube (schwarz) / Lens head screw (black)		M8x12	7381	7381		2	
5	Linsenflanschschraube (schwarz) / Lens head screw (black)		M6x16	7381	7381		4	
6	Halteplatte 2 / Bracket 2						1	
7	Halter Kennzeichenträger / Bracket (license plate holder)						1	
8	Linsenflanschschraube (schwarz) / Lens head screw (black)		M6x12	7381	7381		4	
9	Linsenflanschschraube (schwarz) / Lens head screw (black)		M4x6	7381	7381		2	
10	Kabelhalter 1 / Cable bracket 1						1	
11	Kabelhalter 2 / Cable bracket 2						1	
12	Sechskantmutter (schwarz) / Hexagon nut (black)		M6	985	10511		2	
13	Halteplatte 3 / Bracket 3						1	
14	LED Kennzeichenbeleuchtung / LED license plate light						1	
15	Linsenflanschschraube (schwarz) / Lens head screw (black)		M5x14	7381	7381		3	
16	Kunststoffscheibe / Plastic washer						3	
17	Halter Reflektor / Reflector bracket						1	
18	Reflektor / Reflector						1	
19	Kennzeichenträger / License plate holder						1	
20	U-Scheibe (schwarz) / Washer (black)		M5	9021	7093		3	
21	Sechskantmutter (schwarz) / Hexagon nut (black)		M5	985	10511		3	
22	Moosgummi / Foam rubber						20cm	
23	Schrumpfschlauch / Heat-shrink tubing		6,4mm->3,2mm				30cm	
24	Schrumpfschlauch / Heat-shrink tubing		4,8mm->2,4mm				50cm	
25	Kabeltülle / Cable grommet						1	
26	Schraubensicherung / Threadlocking fluid						1	

LEGENDE/KEY/FILE LÉGENDE



Anbau Tipp
Fitting tip
Astuce de montage



Achtung
Attention
Attention



Vergrößerung
Magnification
Grossissement



Montagepaste
Fitting lubricant
Lubrifiant de montage



Schraube
Screw
Vis



Schraubensicherung
Thread locking fluid
Freinflüts



Drehmoment
Torque
Torque



Reiniger
Cleaner
Nettoyant

26



22

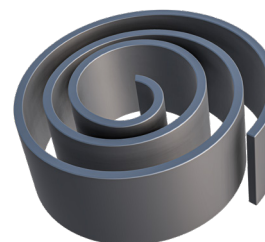

Für die Verkabelung der Kennzeichenbeleuchtung.
For wiring the license plate light.
Pour câbler l'éclairage de la plaque d'immatriculation.

24

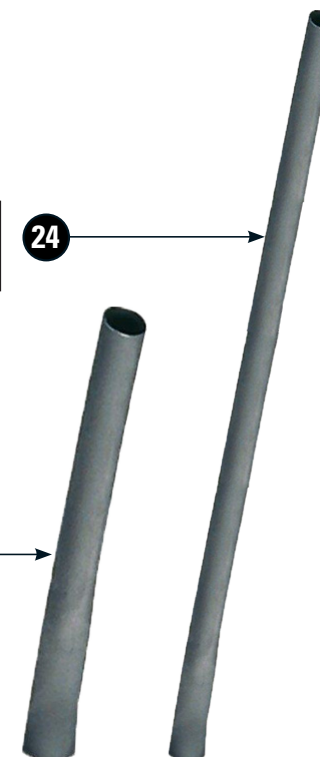

23

Für die Verkabelung des Rücklichts.
For wiring the tail light.
Pour câbler le feu arrière.

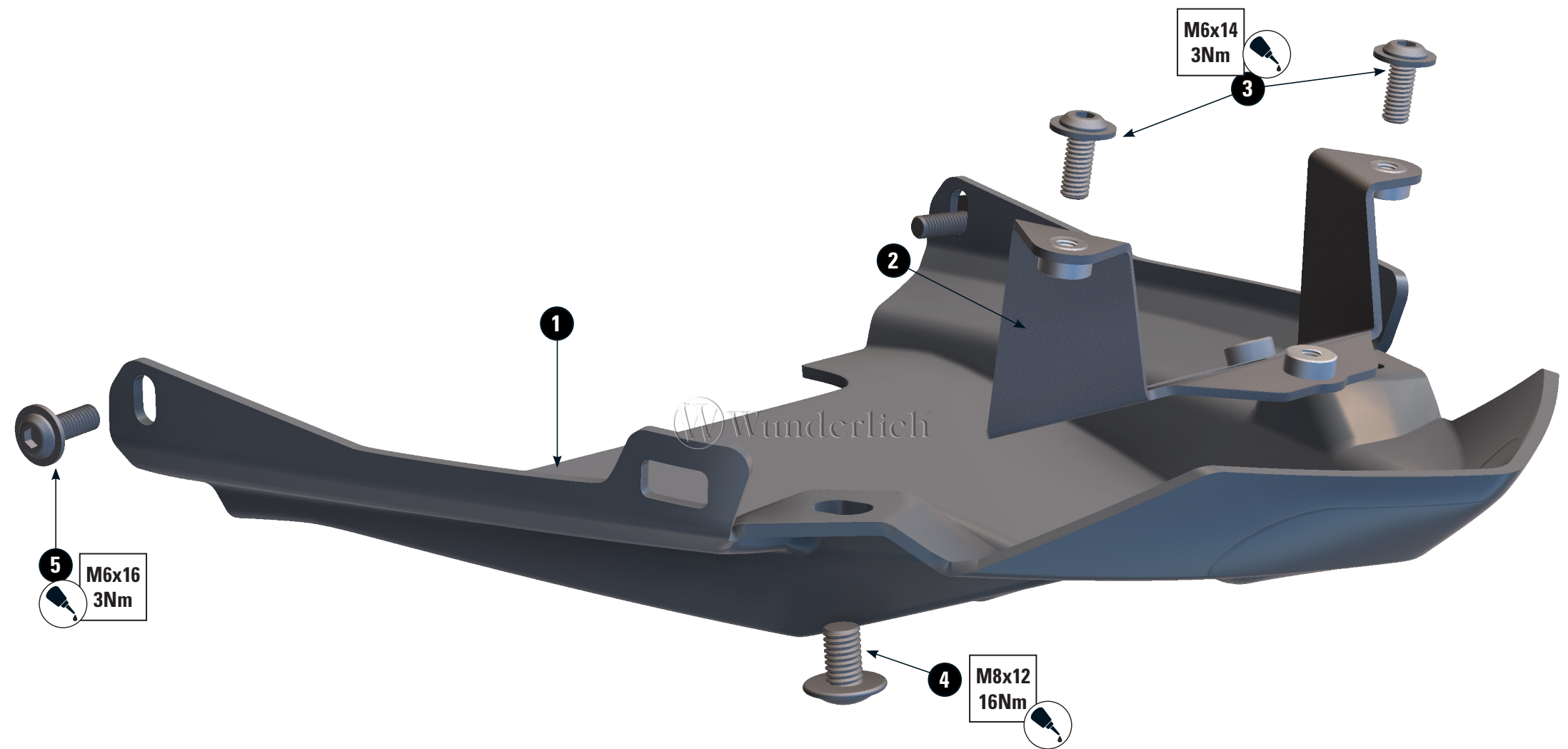

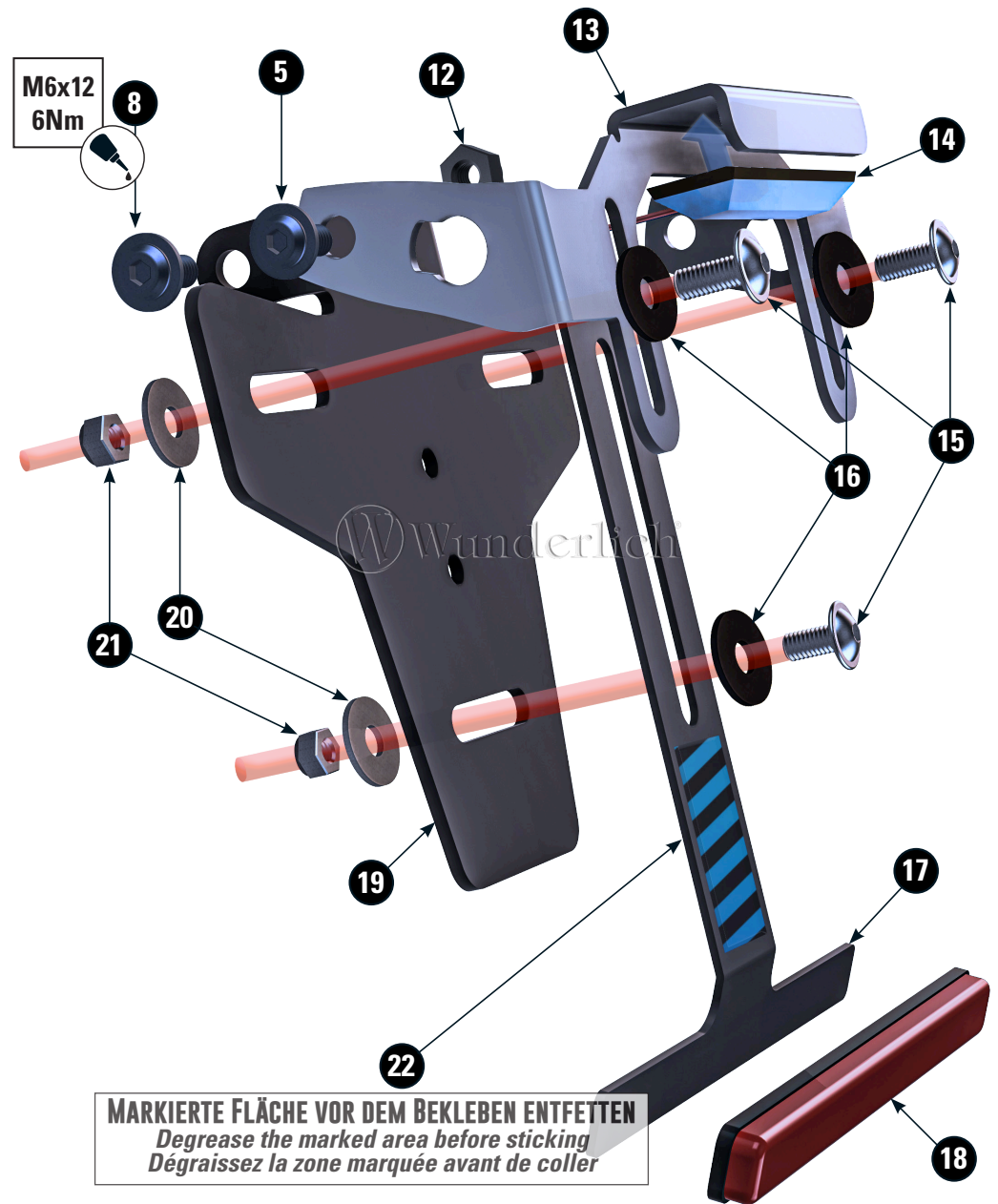
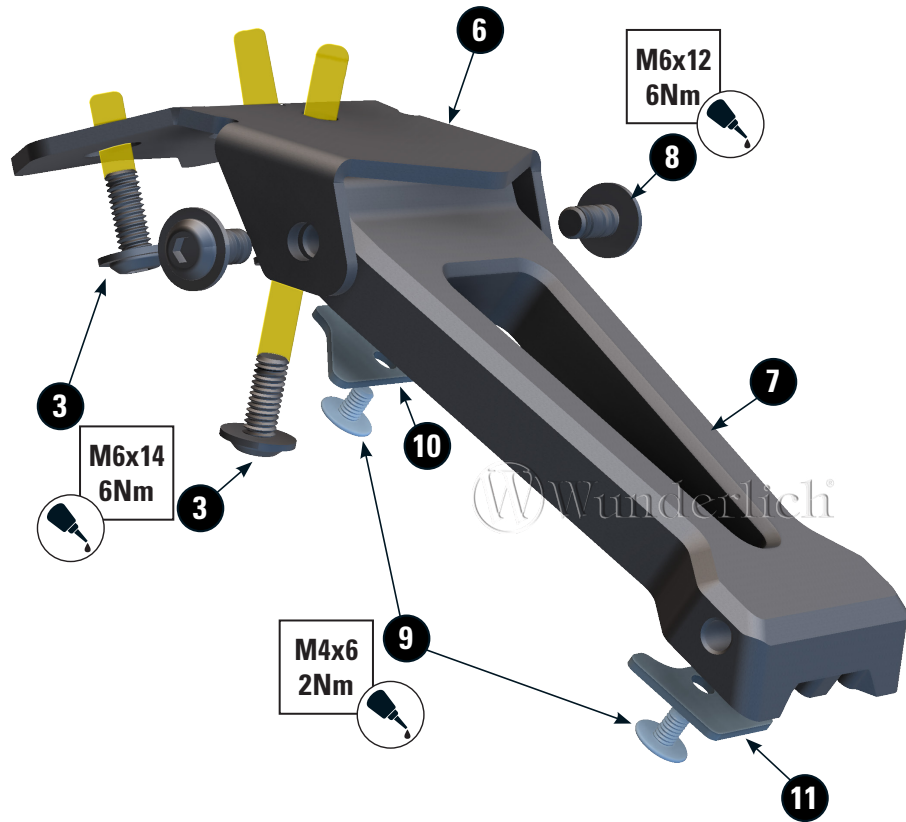

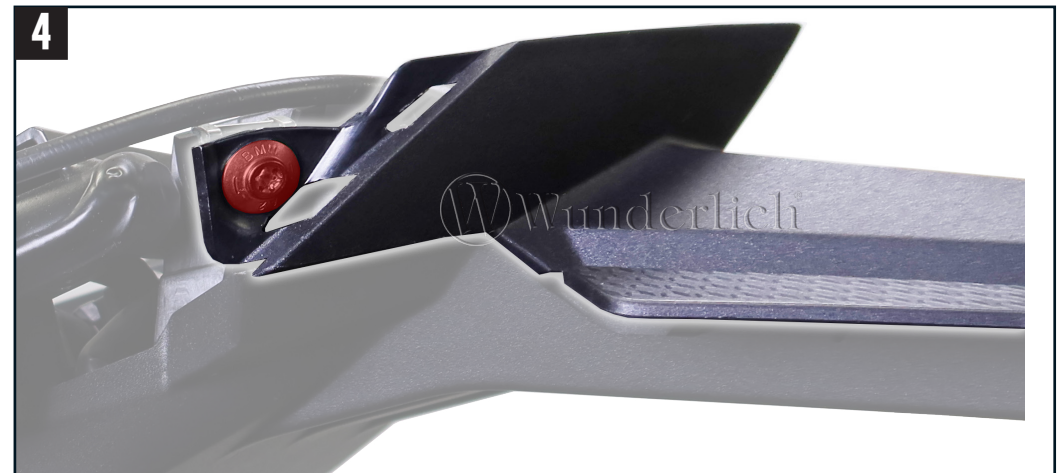
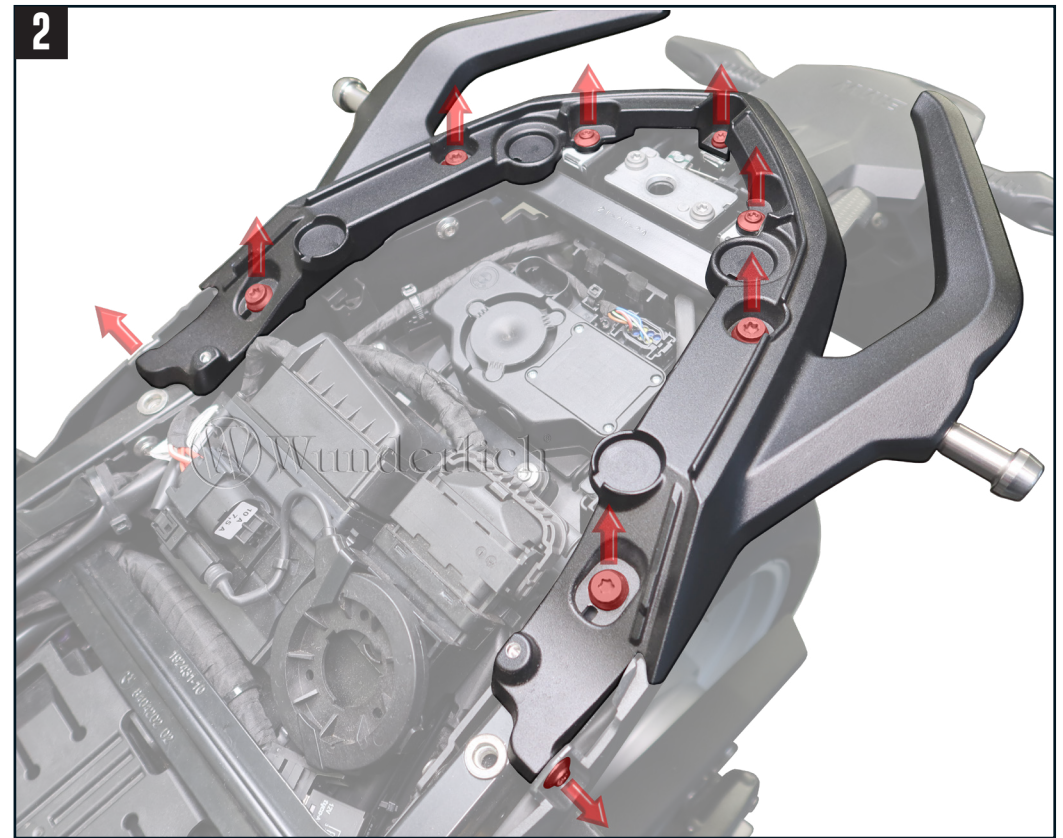
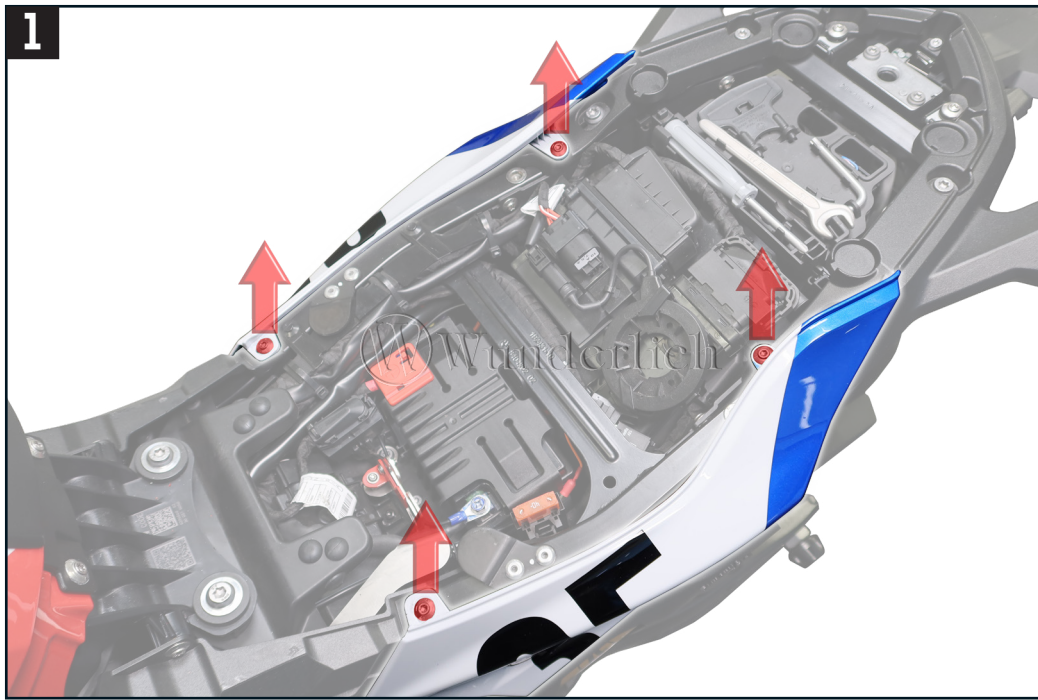

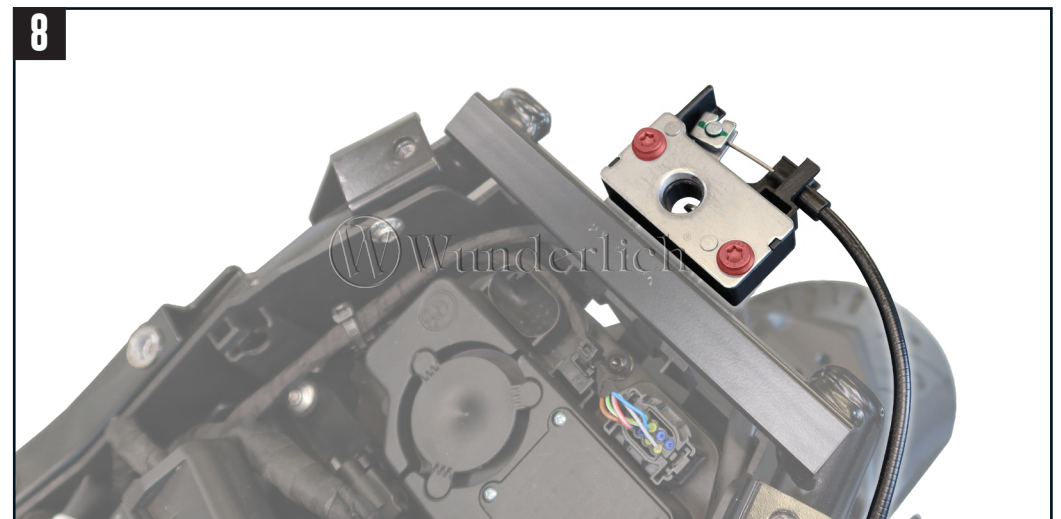
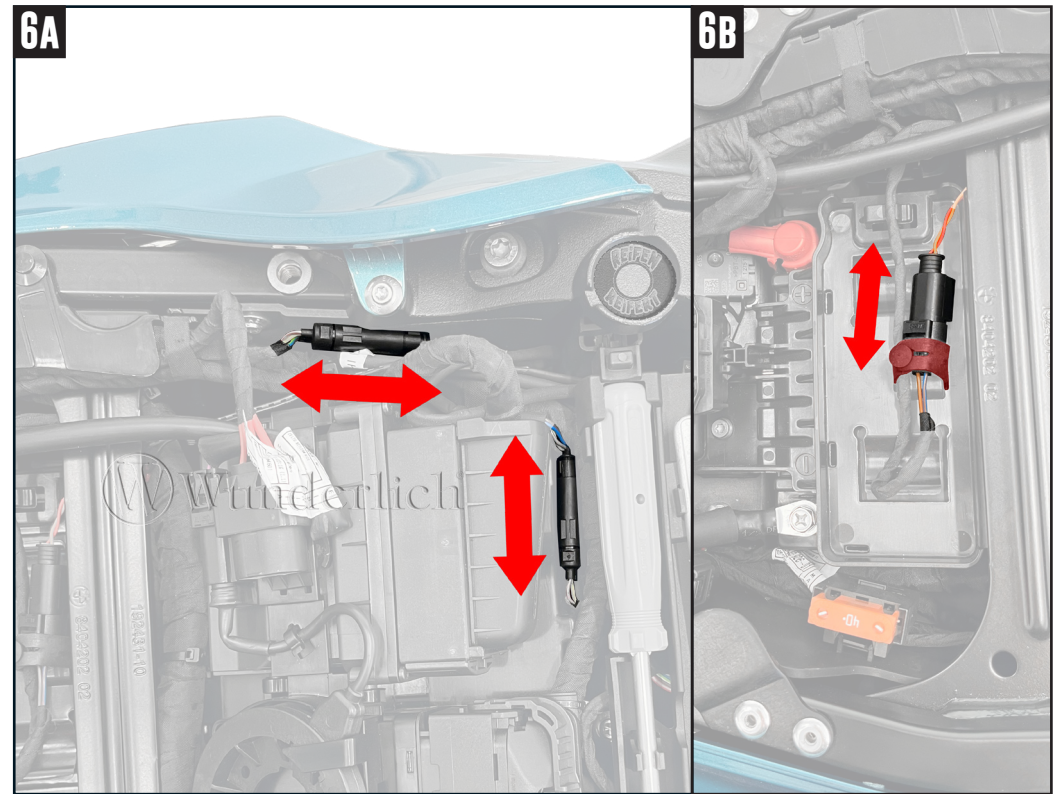

9

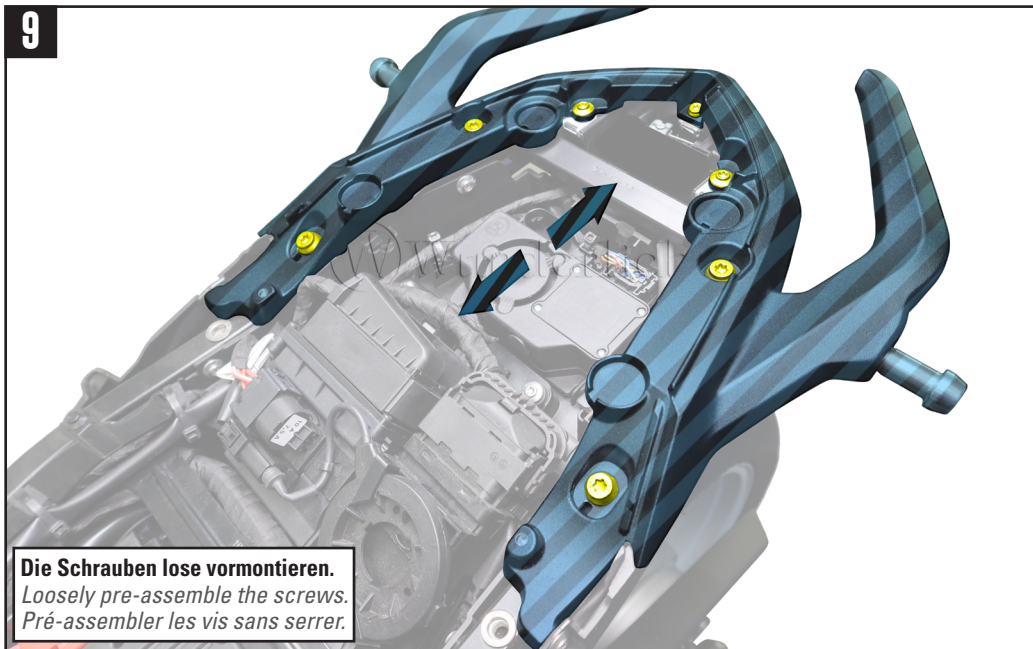

Die Schrauben lose vormontieren.
 Loosely pre-assemble the screws.
 Pré-assembler les vis sans serrer.

10

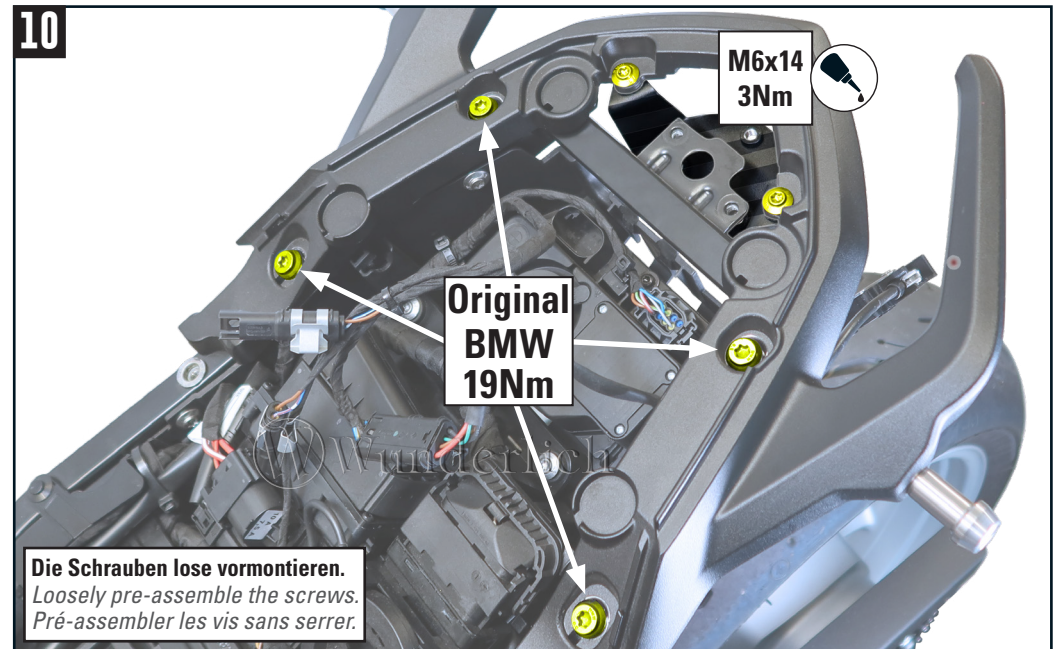

Die Schrauben lose vormontieren.
 Loosely pre-assemble the screws.
 Pré-assembler les vis sans serrer.

11



12

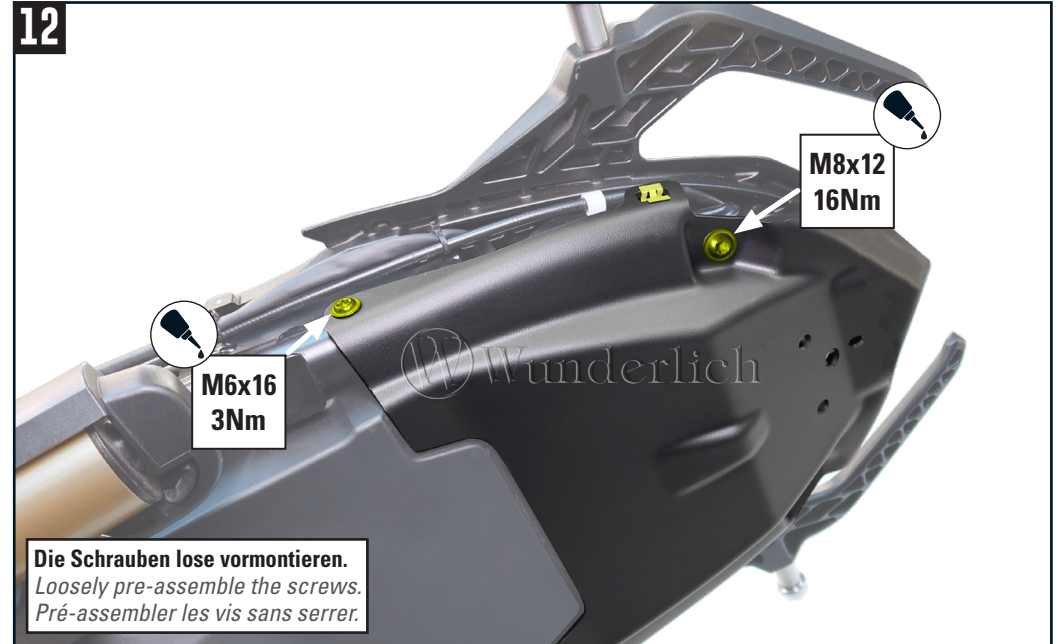

Die Schrauben lose vormontieren.
 Loosely pre-assemble the screws.
 Pré-assembler les vis sans serrer.

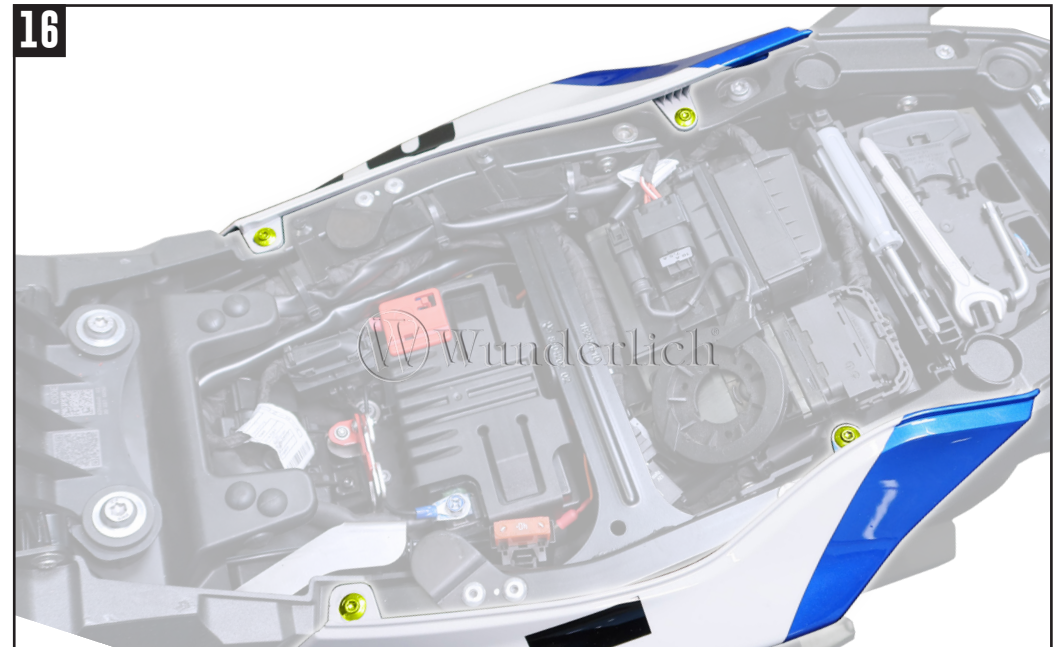
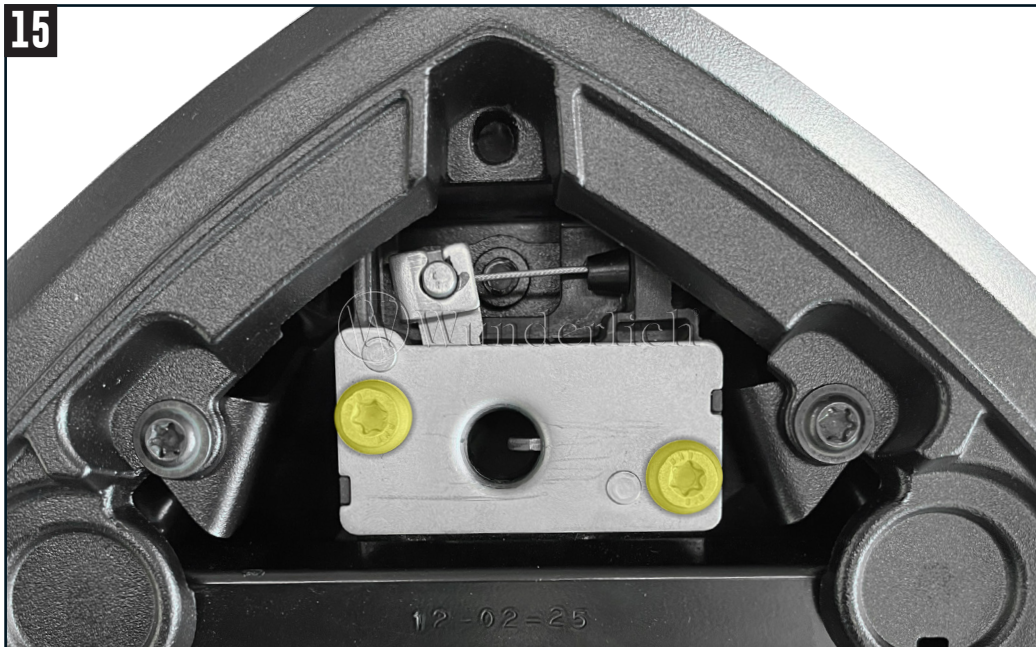



Kennzeichen nach StVZO ausrichten. Auf ausreichenden Abstand zum Reifen achten.
Align the license plate according to the regulation. Observe an adequate distance to the tire.